

SANITARY PRESSURE REDUCING VALVE P130

DESCRIPTION

The ADCA P130 series direct acting, spring-loaded diaphragm sensing, pressure reducing valves are designed for use with clean air, nitrogen, carbon dioxide, oxygen, argon and other gases or liquids compatible with the construction materials and valve design.

This valve is specifically designed for the high purity gas systems found in the pharmaceutical, cosmetic, fine chemical and food & beverage processes.

MAIN FEATURES

Compact design.
Completely machined from 316L stainless steel bar stock, no castings or forgings are used.
FDA / USP Class VI compliant seals.
Non-rising adjustment knob.

STANDARD SURFACE FINISH

Internal wetted parts: $\leq 0,51$ micron Ra – SF1.
External: $\leq 0,76$ micron Ra – SF3.
Other surface conditions see IS PV20.00 E – Technical information.
Ultrasonic cleaning.

OPTIONS:

- Self relieving.
- Leakage line connection 1/8" (captured vent).
- Panel mounting version (thread M45).
- Gauge connection on body.
- Different soft valves for liquids and gases.
- Wall mounting.

USE: Clean air, nitrogen, carbon dioxide, oxygen, argon and other gases or liquids compatible with the construction.

AVAILABLE MODELS: P130.

SIZES: 1/2" to 1"; DN 08 to DN 25.

REGULATING RANGES: 0,2 – 1,5 bar; 0,3 – 3 bar; 2 – 8 bar.

CONNECTIONS: ASME BPE, DIN and ISO clamp ferrules or tube weld (ETO) ends.
Others on request.

PACKAGING: Assembling and packaging in a clean room certified according to ISO 14644-1.
The product is end capped and sealed with recyclable thermo-shrinkable plastic film, to avoid contamination.

INSTALLATION: Horizontal installation recommended.
See IMI – Installation and maintenance instructions.



LIMITING CONDITIONS	
Valve model	P130
Body design conditions	PN 16
Maximum upstream pressure	16 bar
Maximum downstream pressure	8 bar
Minimum downstream pressure	0,2 bar
Maximum design temperature *	150 °C

* Others on request.

CE MARKING – GROUP 2 (PED – European Directive)	
PN 16	Category
1/2" to 1" – DN 08 to 25	SEP

FLOW RATE COEFFICIENTS (m³/h) *

SIZE	BPE		DIN		ISO	
	1/2"	3/4" to 1"	DN 10	DN 15 to DN 25	DN 08	DN 10 to DN 20
Kvs	1,7	3	1,7	3	1,7	3

* Reduced Kvs on request.

DIMENSIONS (mm) ASME BPE

SIZE	A	B	C	D	d1	d2	E	F	H	WEIGHT (kg) *
1/2"	130	36,5	130	80	25	15,75	65	25	9,4	2,9
3/4"	130	36,5	130	80	25	15,75	67,5	25	15,75	2,9
1"	130	36,5	130	80	25	15,75	72,5	50,5	22,1	3,4

* Valves with nylon adjustment knob weigh 0,3 kg less.

DIMENSIONS (mm) DIN

SIZE	A	B	C	D	d1	d2	E	F	H	WEIGHT (kg) *
DN 10	120	36,5	130	80	25	15,75	65	34	10	2,9
DN 15	120	36,5	130	80	25	15,75	67,5	34	16	3
DN 20	120	36,5	130	80	25	15,75	67,5	34	20	3,1
DN 25	120	38,5	128	80	25	15,75	72,5	50,5	26	3,4

* Valves with nylon adjustment knob weigh 0,3 kg less.

Remarks: Clamp ferrules according to DIN 32676-A; Tube weld (ETO) according to DIN 11866-A (DIN 11850-2).

DIMENSIONS (mm) ISO

SIZE	A	B	C	D	d1	d2	E	F	H	WEIGHT (kg) *
DN 08	120	36,5	130	80	25	15,75	65	25	10,3	2,9
DN 10	120	36,5	130	80	25	15,75	67,5	25	14	3
DN 15	120	36,5	130	80	25	15,75	67,5	50,5	18,1	3,2
DN 20	120	38,5	128	80	25	15,75	72,5	50,5	23,7	3,4

* Valves with nylon adjustment knob weigh 0,3 kg less.

Remarks: Clamp ferrules according to DIN 32676-B; Tube weld (ETO) according to DIN 11866-B (ISO 1127).

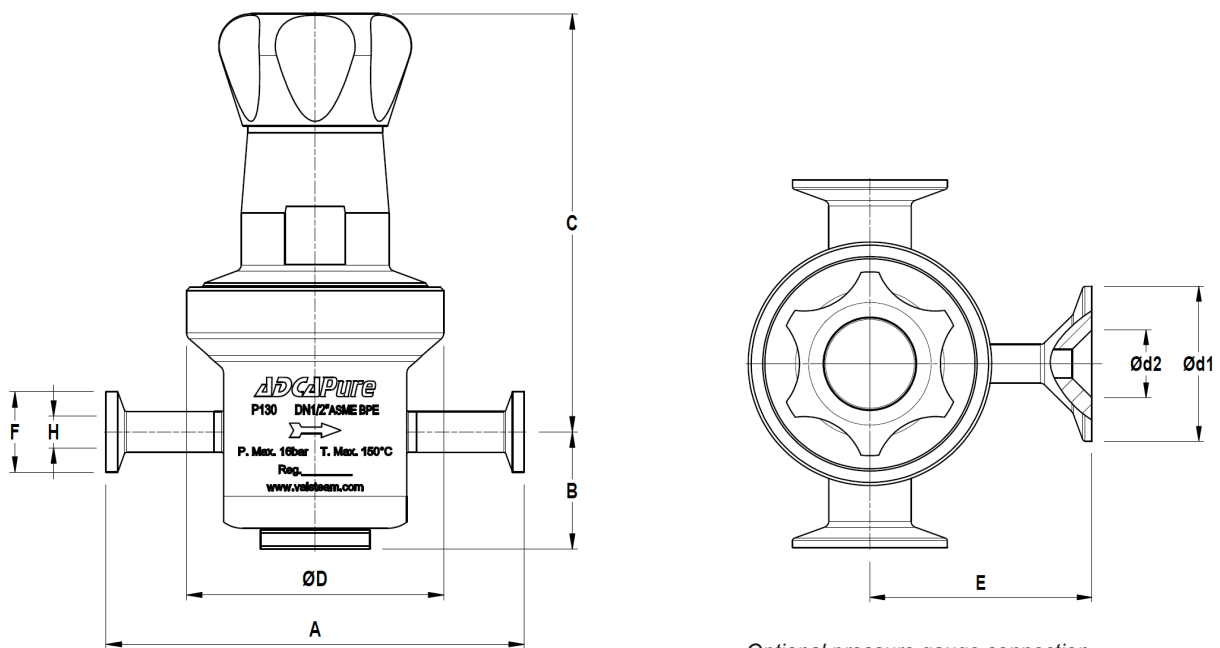

Optional pressure gauge connection.

MATERIALS

POS. N°	DESIGNATION	MATERIAL
1	Valve body	AISI 316L / 1.4404
2	Cover	AISI 316L / 1.4404
3	Seat cover	AISI 316L / 1.4404
4	* O-ring	Viton ; EPDM
5	* Piston	AISI 316L / 1.4404
6	* Valve head	AISI 316L / 1.4404 ; Viton ; PTFE
7	* Valve spring	AISI 316 / 1.4401 electropolished
9	Pusher disc	AISI 316L / 1.4404
10	* Lower diaphragm	PTFE (Gylon)
11	* Upper diaphragm	EPDM
12	Washer	AISI 304 / 1.4301
13	Spring plate	AISI 304 / 1.4301
14	Nut	Stainless steel A2-70
15	* Adjustment spring	AISI 302 / 1.4300
16	Spring plate	AISI 304 / 1.4301
17	Adjustment screw	Brass
18	Retaining washer	Stainless steel A2-70
19	Adjustment knob	AISI 316L / 1.4404 Nylon
20	O-ring	NBR
21	** O-ring	EPDM
22	Bearing	Corrosion resistant steel
23	Ext. bowed shaft ring	Stainless steel
24	Cover nut	Plastic
25	Captured vent ring	AISI 316L / 1.4404
26	O-rings	NBR

* Available spare parts ; ** If applicable.

Remarks: FDA / USP Class VI seals certificate on request.

All valves have a serial number. In case of non-standard valves, this number must be supplied if spare parts are ordered.

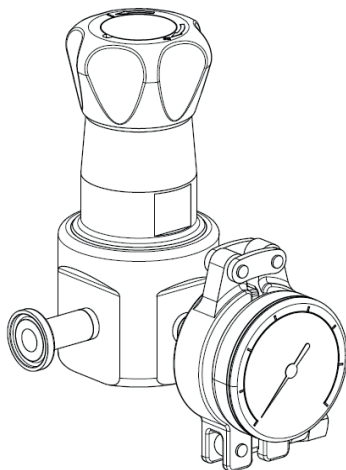
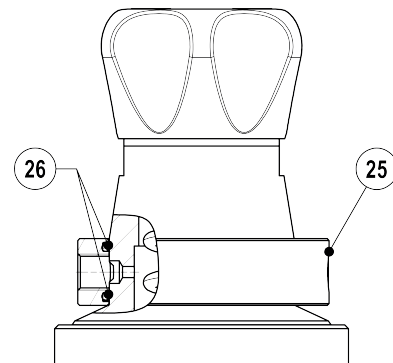
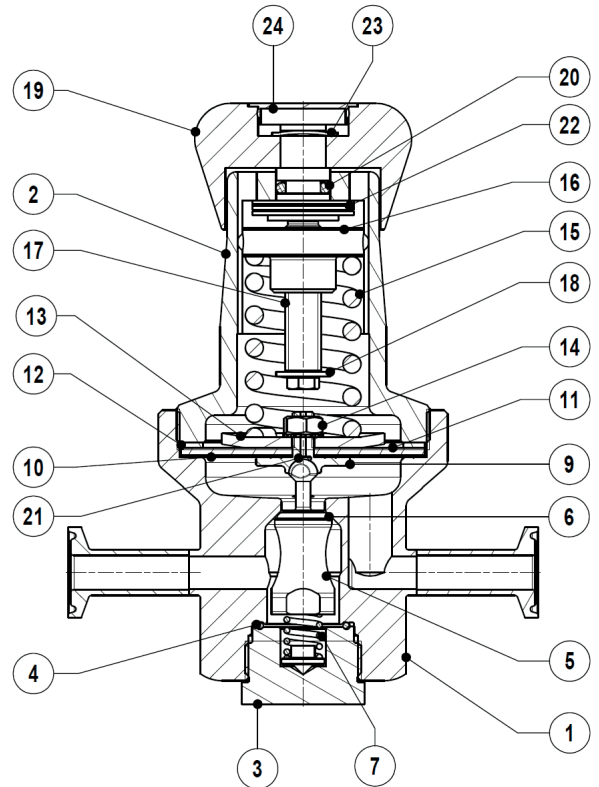

Optional pressure gauge connection.

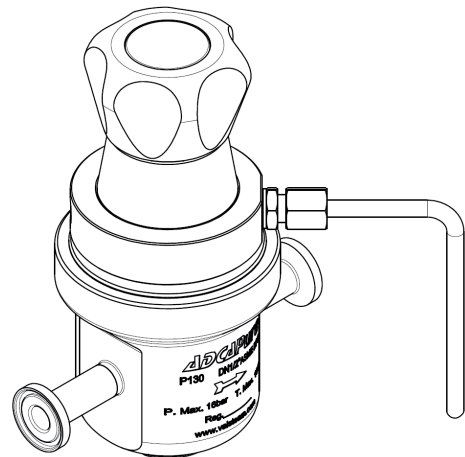

Optional 1/8" captured vent and/or leakage connection (compression fitting and tube not included).

ORDERING CODES P130

Valve model	P13	1	1	T	M	X	I	X	X	X	DI	08
P130 – AISI 316L / 1.4404 diaphragm sensing pressure reducing valve	P13											
Regulating range												
0,2 to 1,5 bar		1										
0,3 to 3 bar		2										
2 to 8 bar		3										
Flow rate coefficient												
Kvs 0,6		1										
Kvs 1		2										
Kvs 1,7		3										
Kvs 3 (only applicable to sizes: 3/4", 1", DIN DN 15 to 25, ISO DN 10 to 20)		6										
Diaphragm												
PTFE (Gylon)				T								
EPDM (non-standard)				E								
Seat material												
Metal to metal (non-standard)					M							
EPDM					E							
PTFE					T							
FPM / Viton					V							
Relieving												
Non-relieving						X						
Relieving (only for non-dangerous gases)						R						
Relieving with captured vent						L						
Adjustment knob and top cap												
Stainless steel adjustment knob							I					
Nylon adjustment knob							P					
Top cap (adjustment screw with cover)							T					
Gauge port options												
Without gauge ports								X				
Tri-clamp gauge port on the left side (rel. to the flow direction) – downstream pressure									7			
Tri-clamp gauge port on the right side (rel. to the flow direction) – downstream pressure										6		
Tri-clamp gauge port on both sides – downstream pressure											5	
Threaded gauge port on the left side (rel. to the flow direction) – downstream pressure – ISO 7 Rp 1/4"												4
Threaded gauge port on the right side (rel. to the flow direction) – downstream pressure – ISO 7 Rp 1/4"												3
Threaded gauge port on both sides – downstream pressure – ISO 7 Rp 1/4"												2
Threaded gauge port on the left side (rel. to the flow direction) – downstream pressure – 1/4" NPT												W
Threaded gauge port on the right side (rel. to the flow direction) – downstream pressure – 1/4" NPT												Y
Threaded gauge port on both sides – downstream pressure – 1/4" NPT												Z
Surface finish a)												
Standard surface finish										X		
Mirror mechanical polished external surfaces (SF1)											P	
Electropolished internal wetted parts (SF5)												E
Special features												
None												X
Degreased for oxygen												O
Pipe connection												
Clamp ferrule ASME BPE												D
Clamp ferrule DIN (DIN 32676-A)												F
Clamp ferrule ISO (DIN 32676-B)												E
Tube weld (ETO) according to ASME BPE												DI
Tube weld (ETO) according to DIN 11866-A (DIN 11850-2)												FI
Tube weld (ETO) according to DIN 11866-B (ISO 1127)												EI
Size												
DN 08												08
DN 10												10
1/2" or DN 15												15
3/4" or DN 20												20
1" or DN 25												25
Special valves / Extras												
Full description or additional codes have to be added in case of non-standard combination												E

a) Consult IS PV20.00 for further details and other surface finish options.