

SANITARY PRESSURE REDUCING VALVES P161

DESCRIPTION

The ADCAPure P161 is a series of angle design direct acting diaphragm sensing pressure reducing valves.

These regulators, available with spring or dome-loading, are designed for use with clean steam, compressed air, water and other gases or liquids compatible with the construction materials and valve design.

MAIN FEATURES

- Spring or dome-loading.
- Non-rising adjustment knob.
- Compact design with clamped body.
- Available with low pressure diaphragm.
- FDA / USP Class VI compliant seals.
- Completely machined from bar stock material, no castings or forgings are used.

STANDARD SURFACE FINISH

- Internal wetted parts: $\leq 0,51 \mu\text{m Ra} - \text{SF1}$.
- External: $\leq 0,76 \mu\text{m Ra} - \text{SF3}$.
- Other surface conditions see TIS.GIA – General information ADCAPure.
- Ultrasonic cleaning.

- OPTIONS:**
- Leakage line connection.
 - Dome-loading.
 - Top cap (adjustment screw with cover).
 - Gauge connection on body.
 - Lock system, allows inline clean-in-place (CIP) and sterilization-in-place (SIP) operations.
 - Different soft sealings for liquids and gases.
 - Degreased for oxygen application.

- USE:**
- Clean steam, compressed air, water and other gases and liquids compatible with the construction.

- AVAILABLE MODELS:**
- P161.

- SIZES:**
- 1/2" to 2"; DN 15 to DN 50.

- REGULATING RANGES:**
- 0,3 to 1,1 bar; 0,8 to 1,5 bar; 1 to 3 bar; 1,5 to 5 bar.

- CONNECTIONS:**
- ASME BPE, DIN and ISO clamp ferrules or tube weld (ETO) ends. Others on request.

- PACKAGING:**
- Assembling and packaging in a clean room certified according to ISO 14644-1.
 - The product is end capped and sealed with recyclable thermo-shrinkable plastic film, to avoid contamination.

- INSTALLATION:**
- Horizontal installation. Vertical inlet and horizontal outlet. See IMI – Installation and maintenance instructions.



CE MARKING – GROUP 2 (PED – European Directive)	
PN 10	Category
1/2" to 2" – DN 15 to 50	SEP

LIMITING CONDITIONS *	
Maximum allowable pressure	10 bar
Maximum upstream pressure	8 bar
Maximum downstream pressure	5 bar
Minimum downstream pressure **	0,3 bar
Maximum operating temperature ***	180 °C

* Other limits on request. Maximum operating conditions may be limited by the valve end connections due to normative restrictions.

** For tight shut off, with adjustment spring relaxed, ensure a minimum downstream pressure of 0,2 bar.

*** See "Ordering Codes" table for restrictions.

FLOW RATE COEFFICIENTS (m³/h)

SIZE	ASME BPE					DIN						ISO						
	1/2"	3/4"	1"	1 1/2"	2"	DN 15	DN 20	DN 25	DN 32	DN 40	DN 50	DN 15	DN 20	DN 25	DN 32	DN 40		
Kvs	1,3	3	4,2	7	7	13	2,1	3	4,2	4,2	7	7	13	2,1	4,2	4,2	7	7

OPTIONS

LEAKAGE LINE CONNECTION	DOME-LOADING	TOP CAP	GAUGE CONNECTION	LOCK SYSTEM

DIMENSIONS

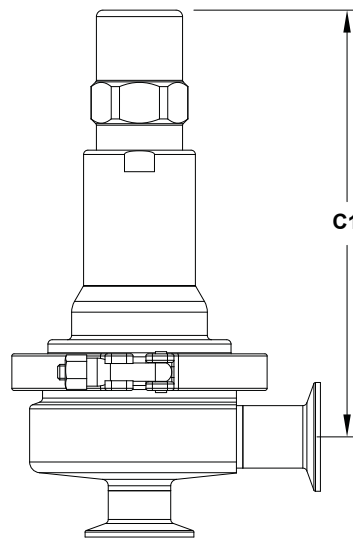
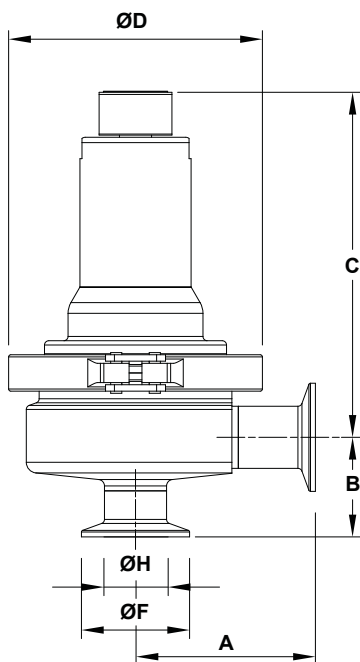

Optional top cap

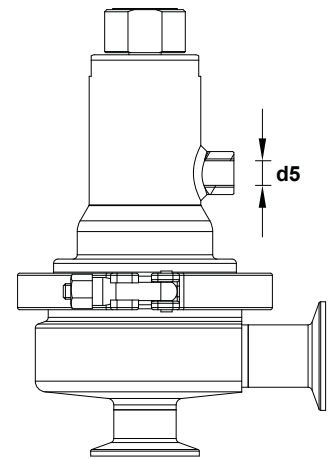

Optional leakage line connection

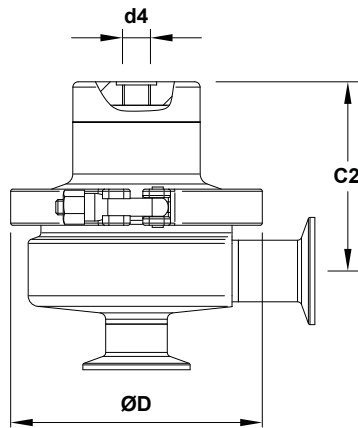

Optional dome-loading

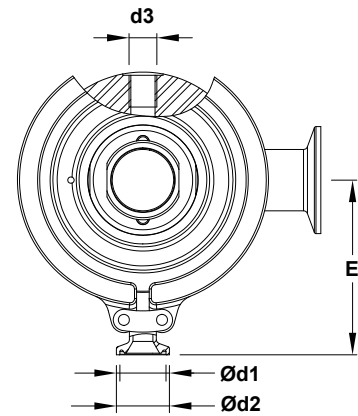

Optional gauge connection

DIMENSIONS – ASME BPE (mm)

REGULATING RANGES 0,8 to 1,5 bar, 1 to 3 bar and 1,5 to 5 bar																REGULATING RANGE 0,3 to 1,1 bar			
SIZE	A	B	C	C1	C2	ØD	Ød1	Ød2	d3	d4	d5	E	ØF	ØH	WGT. (kg)	A	ØD	E	WGT. (kg)
1/2"	77	53	156	193	84	119	15,75	25	1/4"	1/4"	1/4"	83	25	9,4	4,1	85	134	91	4,9
3/4"	77	56	160	197	88	119	15,75	25	1/4"	1/4"	1/4"	83	25	15,8	4,4	85	134	91	5,1
1"	77	52	163	200	91	119	15,75	25	1/4"	1/4"	1/4"	83	50,4	22,1	4,6	85	134	91	5,4
1 1/2"	85	61	204	247	124	134	15,75	25	1/4"	1/4"	1/4"	96	50,4	34,8	8	101	170	109	11,1
2"	85	67	207	244	127	134	15,75	25	1/4"	1/4"	1/4"	96	63,9	47,5	8,6	101	170	109	12

DIMENSIONS – DIN (mm)

REGULATING RANGES 0,8 to 1,5 bar, 1 to 3 bar and 1,5 to 5 bar																REGULATING RANGE 0,3 to 1,1 bar			
SIZE	A	B	C	C1	C2	ØD	Ød1	Ød2	d3	d4	d5	E	ØF	ØH	WGT. (kg)	A	ØD	E	WGT. (kg)
DN 15	77	45	160	197	88	119	15,75	25	1/4"	1/4"	1/4"	83	34	16	4,4	85	134	91	5,1
DN 20	77	40	158	195	86	119	15,75	25	1/4"	1/4"	1/4"	83	34	20	4,3	85	134	91	4,9
DN 25	84	47	161	198	89	119	15,75	25	1/4"	1/4"	1/4"	83	50,5	26	4,6	92	134	91	5,3
DN 32	84	50	163	200	91	119	15,75	25	1/4"	1/4"	1/4"	83	50,5	32	4,8	84	134	83	5,5
DN 40	93	69	202	239	122	134	15,75	25	1/4"	1/4"	1/4"	96	50,5	38	8	109	170	109	11
DN 50	93	75	206	243	126	134	15,75	25	1/4"	1/4"	1/4"	96	64	50	8,6	109	170	109	12

Remarks: Clamp ferrules according to DIN 32676-A. Tube weld (ETO) according to DIN 11866-A (DIN 11850-2).

DIMENSIONS – ISO (mm)

REGULATING RANGES 0,8 to 1,5 bar, 1 to 3 bar and 1,5 to 5 bar																REGULATING RANGE 0,3 to 1,1 bar			
SIZE	A	B	C	C1	C2	ØD	Ød1	Ød2	d3	d4	d5	E	ØF	ØH	WGT. (kg)	A	ØD	E	WGT. (kg)
DN 15	84	43	159	196	87	119	15,75	25	1/4"	1/4"	1/4"	83	50,5	18,1	4,4	92	134	91	5,1
DN 20	84	46	162	199	90	119	15,75	25	1/4"	1/4"	1/4"	83	50,5	23,7	4,6	92	134	91	5,4
DN 25	84	49	164	201	92	119	15,75	25	1/4"	1/4"	1/4"	83	50,5	29,7	4,8	92	134	91	5,6
DN 32	93	70	202	239	122	134	15,75	25	1/4"	1/4"	1/4"	96	64	38,4	8,2	109	170	109	11,3
DN 40	93	75	206	243	126	134	15,75	25	1/4"	1/4"	1/4"	96	64	44,3	8,8	109	170	109	12,1

Remarks: Clamp ferrules according to DIN 32676-B. Tube weld (ETO) according to DIN 11866-B (ISO 1127).

MATERIALS

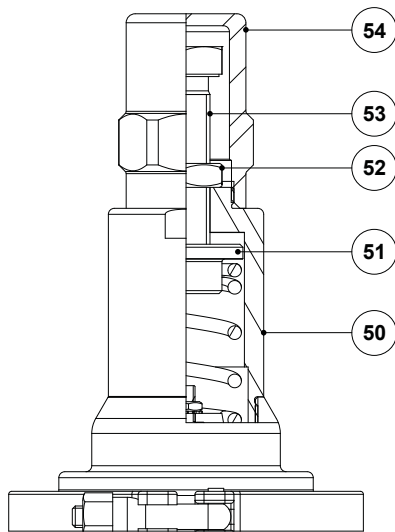
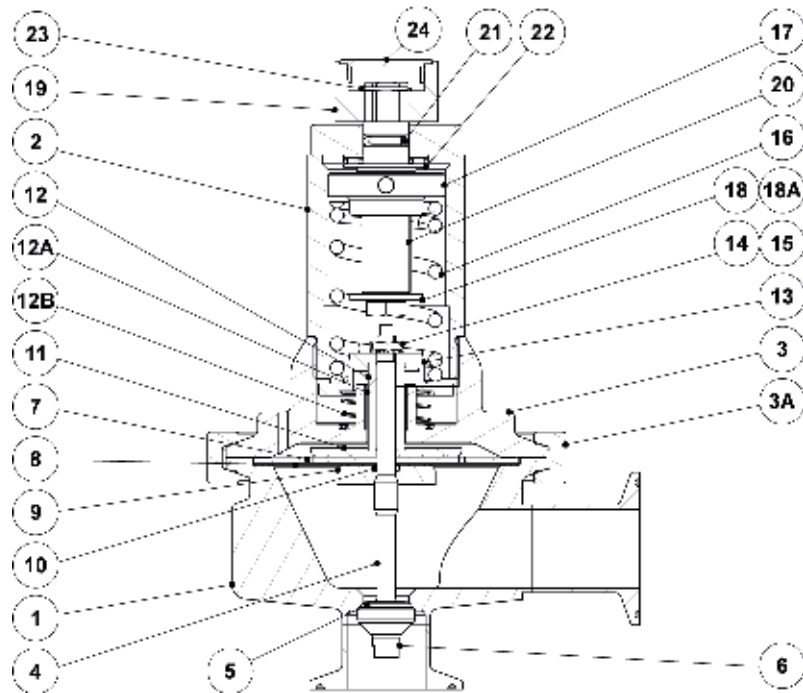

Optional top cap

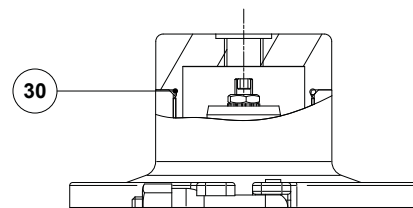

Optional dome-loading

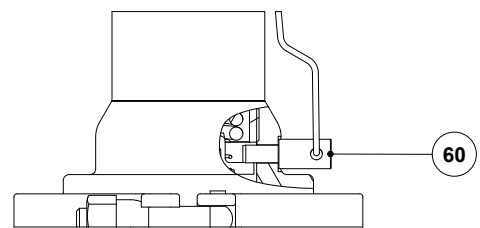

Optional lock system

MATERIALS		
POS. N°	DESIGNATION	MATERIAL
1	Valve body	AISI 316L / 1.4404
2	Cover	AISI 316L / 1.4404
3	Intermediate flange	AISI 316L / 1.4404
3A	Clamp	AISI 316 / 1.4401
4	* Valve stem	AISI 316L / 1.4404
5	* Valve seal	** EPDM; PTFE; FPM
6	* Valve plug	AISI 316L / 1.4404
7	* Upper diaphragm	EPDM
8	* Lower diaphragm	PTFE (Gylon)
9	Lower diaphragm plate	AISI 316L / 1.4404
10	* O-ring	** EPDM; PTFE; FPM
11	Upper diaphragm plate	AISI 316L / 1.4404
12	Stem guide	AISI 316L / 1.4404
12A	Plain bearing	Bronze
12B	Spring	AISI 302 / 1.4300
13	Spring plate	AISI 316L / 1.4404
14	Nut	Stainless steel A2-70
15	* Washer	Stainless steel A2
16	* Adjustment spring	AISI 302 / 1.4300
17	Top spring plate	AISI 316L / 1.4404
18	Washer	Stainless steel A2
18A	Bolt	Stainless steel A2-70
19	Adjustment knob	AISI 316L / 1.4404
20	Adjustment screw	Brass
21	O-ring	NBR
22	Bearing	Corrosion resistant steel
23	Shaft ring	Stainless steel
24	Cover nut	Plastic
30	* O-ring	EPDM
50	Cover	AISI 316L / 1.4404
51	Spring guide	Brass
52	Lock nut	Stainless steel A2-70
53	Adjustment screw	Stainless steel A2-70
54	Top cap	AISI 316L / 1.4404
60	Locking pin	AISI 316L / 1.4404

* Available spare parts. ** Others on request.

Remarks: FDA / USP Class VI seals certificate on request.

All valves have a serial number. In case of non-standard valves, this number must be supplied if spare parts are ordered.

ORDERING CODES P161

Valve model	P16	1	3	1	T	M	I	X	X	X	DI	15	E
P161 – AISI 316L / 1.4404 diaphragm sensing pressure reducing valve	P16												
Valve series													
Series 1		1											
Regulating range													
0,3 to 1,1 bar			3										
0,8 to 1,5 bar			4										
1 to 3 bar			5										
1,5 to 5 bar			6										
0,8 to 5 bar (dome-loading) a)			A										
0,3 to 1,1 bar (dome-loading) a)			B										
Flow rate coefficient													
Kvs 1,3 (only applicable to ASME BPE 1/2" size)				1									
Kvs 2,1 (applicable to sizes DIN DN 15 and ISO DN 15)				2									
Kvs 3 (applicable to sizes ASME BPE 3/4" and DIN DN 20)				3									
Kvs 4,2 (applicable to sizes ASME BPE 1", DIN DN 25 to DN 32 and ISO DN 20 to DN 25)				4									
Kvs 7 (applicable to sizes ASME BPE 1 1/2" to 2", DIN DN 40 to DN 50 and ISO DN 32 to DN 40)				6									
Kvs 13 (applicable to sizes ASME BPE 2" and DIN DN 50)				8									
Diaphragm													
PTFE (Gylon)					T								
EPDM (non-standard) – Tmax 150 °C					E								
Valve sealing b)													
Metal to metal (non-standard, except in ASME BPE 1/2" size)						M							
EPDM – Tmax 150 °C (180 °C with steam and hot water)							E						
PTFE								T					
FPM / Viton (USP Class VI on request)									V				
Adjustment knob, top cap and leakage line connection													
Stainless steel adjustment knob										I			
Top cap (adjustment screw with cover)											T		
Stainless steel adjustment knob w/ ISO 228 G 1/4" leakage line connection												L	
Stainless steel adjustment knob w/ 1/4" NPT leakage line connection													M
Top cap (adjustment screw with cover) w/ ISO 228 G 1/4" leakage line connection													U
Top cap (adjustment screw with cover) w/ 1/4" NPT leakage line connection													V
Dome-loading – ISO 228 G 1/4" c)													X
Dome-loading – 1/4" NPT c)													C
Gauge connections													
Without gauge connections													X
Tri-clamp gauge connection on the left side (relative to flow direction) – downstream pressure													7
Tri-clamp gauge connection on the right side (relative to flow direction) – downstream pressure													6
Tri-clamp gauge connections on both sides – downstream pressure													5
Threaded gauge connection on the left side (relative to flow direction) – downstream pressure – ISO 228 G 1/4"													4
Threaded gauge connection on the right side (relative to flow direction) – downstream pressure – ISO 228 G 1/4"													3
Threaded gauge connections on both sides – downstream pressure – ISO 228 G 1/4"													2
Threaded gauge connection on the left side (relative to flow direction) – downstream pressure – 1/4" NPT													W
Threaded gauge connection on the right side (relative to flow direction) – downstream pressure – 1/4" NPT													Y
Threaded gauge connections on both sides – downstream pressure – 1/4" NPT													Z
Surface finish d)													
Standard surface finish													X
Mirror mechanical polished external surfaces (SF1)													P
Electropolished internal wetted parts (SF5)													E
Special features													
None													X
Degreased for oxygen													O
CIP / SIP lock system													C
Pipe connection													
Clamp ferrule ASME BPE													D
Clamp ferrule DIN (DIN 32676-A)													F
Clamp ferrule ISO (DIN 32676-B)													E
Tube weld (ETO) according to ASME BPE													DI
Tube weld (ETO) according to DIN 11866-A (DIN 11850-2)													FI
Tube weld (ETO) according to DIN 11866-B (ISO 1127)													EI
Size													
1/2" or DN 15													15
3/4" or DN 20													20
1" or DN 25													25
DN 32													32
1 1/2" or DN 40													40
2" or DN 50													50
Special construction / Additional options													
Full description or additional codes have to be added in case of a non-standard combination													E

a) The loading control pressure can be up to a maximum of 0,2 bar above the required downstream pressure. b) ASME BPE 1/2" size is only available with metal to metal sealing. c) Mandatory in case of dome-loading. d) Consult TIS.GIA – General information ADCAPure – for further details and other surface finish options.