

## SANITARY PRESSURE SUSTAINING VALVES PS130

### DESCRIPTION

The ADCAPure PS130 is a series of direct acting, diaphragm sensing pressure sustaining valves.

These regulators, available with spring or dome-loading, are designed for use with clean air, nitrogen, carbon dioxide, oxygen, argon and other gases or liquids compatible with the construction materials and valve design.

Specifically designed for the high purity gas systems found in the pharmaceutical, cosmetic, fine chemical and food & beverage processes.

### MAIN FEATURES

Compact design.

Non-rising adjustment knob.

FDA / USP Class VI compliant seals.

Completely machined from 316L stainless steel bar stock, no castings or forgings are used.

### STANDARD SURFACE FINISH

Internal wetted parts:  $\leq 0,51 \mu\text{m Ra} - \text{SF1}$ .

External:  $\leq 0,76 \mu\text{m Ra} - \text{SF3}$ .

Other surface conditions see TIS.GIA – General information ADCAPure.

Ultrasonic cleaning.

**OPTIONS:**

- Leakage line connection.
- Panel mounting.
- Dome-loading.
- Top cap (adjustment screw with cover).
- Gauge connection on body.
- Wall mounting.
- Different soft sealings for liquids and gases.
- Degreased for oxygen application.

**USE:** Clean air, nitrogen, carbon dioxide, oxygen, argon and other gases or liquids compatible with the construction.

**AVAILABLE MODELS:** PS130.

**SIZES:** 1/2" to 1"; DN 08 to DN 25.

**REGULATING RANGES:** 0,2 – 1,5 bar; 0,3 – 3 bar; 2 – 8 bar.

**CONNECTIONS:** ASME BPE, DIN and ISO clamp ferrules or tube weld (ETO) ends. Others on request.

**PACKAGING:** Assembling and packaging in a clean room certified according to ISO 14644-1. The product is end capped and sealed with recyclable thermo-shrinkable plastic film, to avoid contamination.

**INSTALLATION:** Horizontal installation is recommended. See IMI – Installation and maintenance



#### CE MARKING – GROUP 2 (PED – European Directive)

PN 16	Category
1/2" to 1" – DN 08 to 25	SEP

#### LIMITING CONDITIONS \*

Maximum allowable pressure	12 bar
Maximum upstream pressure	8 bar
Minimum upstream pressure	0,2 bar
Maximum operating temperature	150 °C

\* Other limits on request. Maximum operating conditions may be limited by the valve end connections due to

**FLOW RATE COEFFICIENTS (m<sup>3</sup>/h) \***

SIZE	ASME BPE		DIN		ISO	
	1/2"	3/4" to 1"	DN 10	DN 15 to 25	DN 08	DN 10 to 20
Kvs	1,7	3	1,7	3	1,7	3

\* Reduced Kvs on request.

**OPTIONS**

LEAKAGE LINE CONNECTION	PANEL MOUNTING	DOME-LOADING
TOP CAP	GAUGE CONNECTION	WALL MOUNTING

**DIMENSIONS**

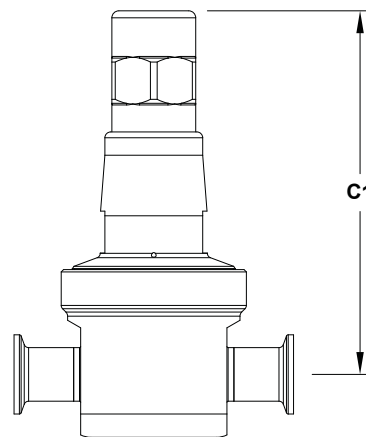
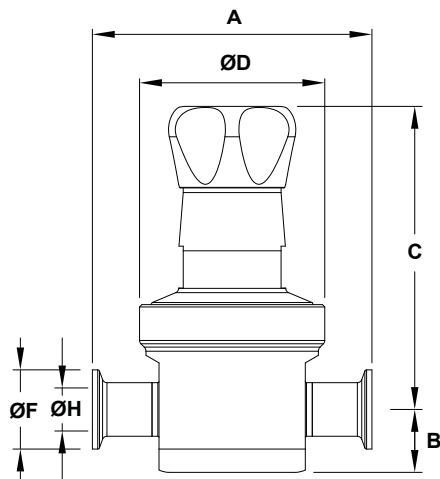

Optional top cap

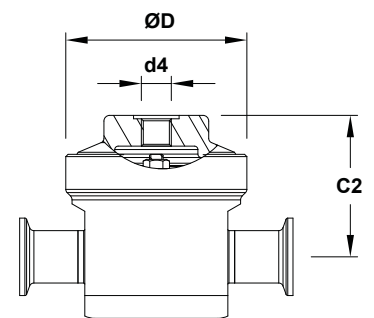

Optional dome-loading

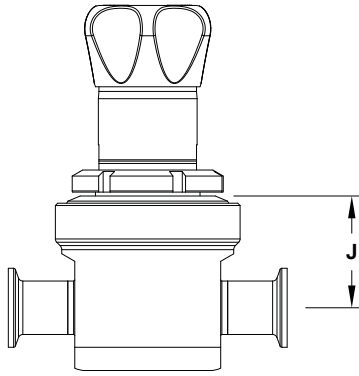

Optional panel mounting

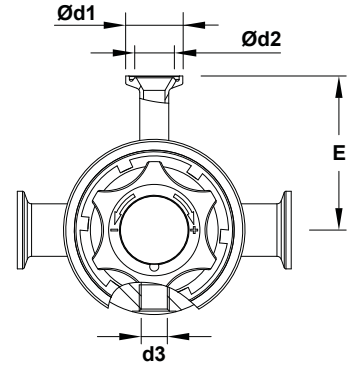
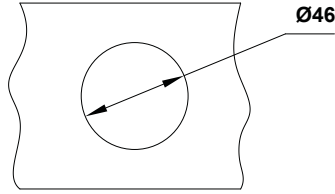

Optional gauge connection

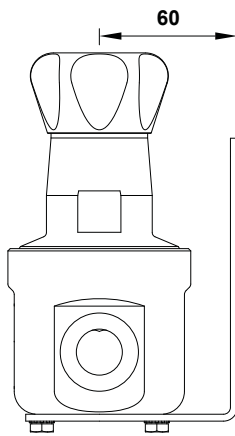

Optional wall mounting

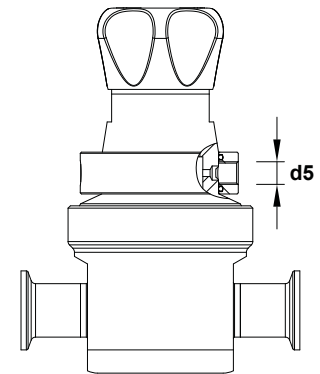
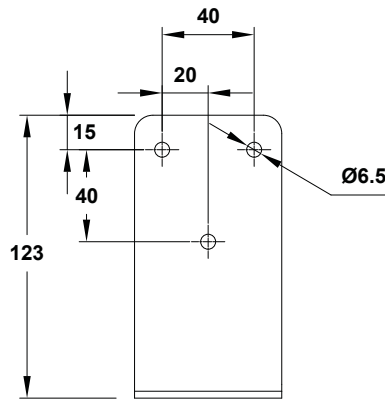

Optional leakage line connection

**DIMENSIONS – ASME BPE (mm)**

SIZE	A	B	C	C1	C2	ØD	Ød1	Ød2	d3	d4	d5	E	ØF	ØH	J	WGT. (kg)
1/2"	130	30	127	156	62	80	25	15,75	1/4"	1/4"	1/8"	65	25	9,4	48	2,9
3/4"	130	30	127	156	62	80	25	15,75	1/4"	1/4"	1/8"	67,5	25	15,8	48	2,9
1"	130	30	127	156	62	80	25	15,75	1/4"	1/4"	1/8"	72,5	50,4	22,1	48	3,4

\* Valves with nylon adjustment knob weigh 0,3 kg less.

**DIMENSIONS – DIN (mm)**

SIZE	A	B	C	C1	C2	ØD	Ød1	Ød2	d3	d4	d5	E	ØF	ØH	J	WGT. (kg)
DN 10	120	30	127	156	62	80	25	15,75	1/4"	1/4"	1/8"	65	34	10	48	2,9
DN 15	120	30	127	156	62	80	25	15,75	1/4"	1/4"	1/8"	67,5	34	16	48	3
DN 20	120	30	127	156	62	80	25	15,75	1/4"	1/4"	1/8"	67,5	34	20	48	3,1
DN 25	120	32	125	156	62	80	25	15,75	1/4"	1/4"	1/8"	72,5	50,5	26	48	3,4

\* Valves with nylon adjustment knob weigh 0,3 kg less.

Remarks: Clamp ferrules according to DIN 32676-A. Tube weld (ETO) according to DIN 11866-A (DIN 11850-2).

**DIMENSIONS – ISO (mm)**

SIZE	A	B	C	C1	C2	ØD	Ød1	Ød2	d3	d4	d5	E	ØF	ØH	J	WGT. (kg)
DN 08	120	30	127	156	62	80	25	15,75	1/4"	1/4"	1/8"	65	25	10,3	48	2,9
DN 10	120	30	127	156	62	80	25	15,75	1/4"	1/4"	1/8"	67,5	25	14	48	3
DN 15	120	30	127	156	62	80	25	15,75	1/4"	1/4"	1/8"	67,5	50,5	18,1	48	3,2
DN 20	120	32	125	156	62	80	25	15,75	1/4"	1/4"	1/8"	72,5	50,5	23,7	48	3,4

\* Valves with nylon adjustment knob weigh 0,3 kg less.

Remarks: Clamp ferrules according to DIN 32676-A. Tube weld (ETO) according to DIN 11866-B (DIN 11850-2).

**MATERIALS**

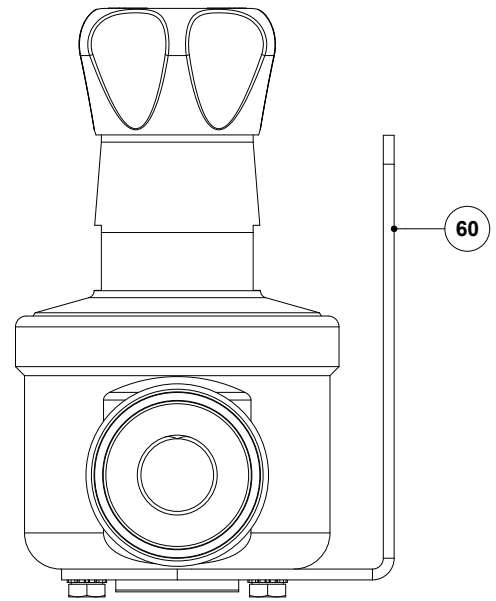
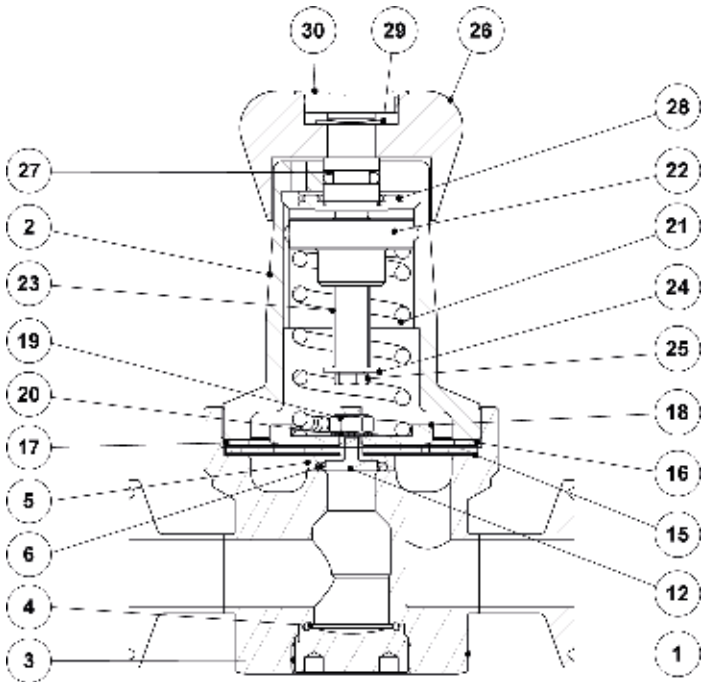

*Optional wall mounting*

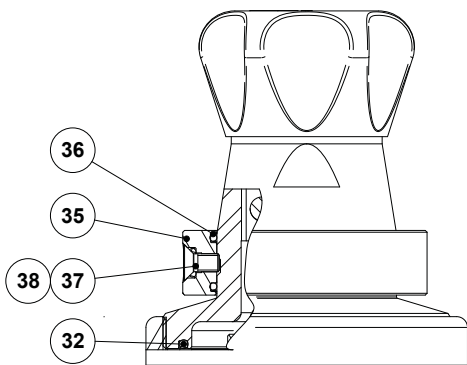

*Optional leakage line connection*

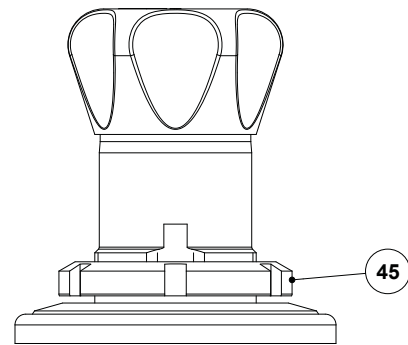

*Optional panel mounting*

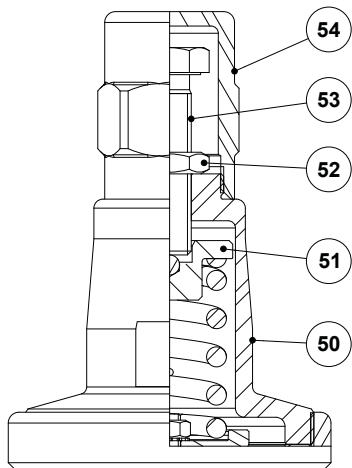

*Optional top cap*

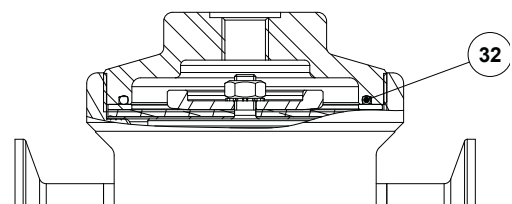

*Optional dome loading*

MATERIALS		
POS. N°	DESIGNATION	MATERIAL
1	Valve body	AISI 316L / 1.4404
2	Cover	AISI 316L / 1.4404
3	Bottom cover	AISI 316L / 1.4404
4	* O-ring	** EPDM
5	* Plug	AISI 316L / 1.4404
6	* Valve seal	** EPDM; PTFE; FPM
12	* Retainer	AISI 316L / 1.4404
15	* Lower diaphragm	PTFE (Gylon)
16	* Upper diaphragm	EPDM
17	Washer	AISI 304 / 1.4301
18	* Plate	AISI 304 / 1.4301
19	* Nut	Stainless steel A2-70
20	* Washer	Stainless steel A2
21	* Adjustment spring	AISI 302 / 1.4300
22	Spring plate	AISI 316 / 1.4401
23	Adjustment screw	Brass
24	Washer	Stainless steel A2
25	Bolt	Stainless steel A2-70
26	Adjustment knob	AISI 316L / 1.4404; Nylon
27	O-ring	NBR
28	Bearing	Corrosion resistant steel
29	Shaft ring	Stainless steel
32	* O-ring	EPDM
35	Leakage line ring	AISI 316 / 1.4401
36	O-ring	NBR
37	Bolt	AISI 304 / 1.4301
38	O-ring	FPM
45	Lock nut	CF8M / 1.4408
50	Cover	AISI 316L / 1.4404
51	Spring guide	Brass
52	Lock nut	Stainless steel A2-70
53	Adjustment screw	Stainless steel A2-70
54	Top cap	AISI 316L / 1.4404
60	Support plate	AISI 316L / 1.4404

\* Available spare parts. \*\* Others on request.

Remarks: FDA / USP Class VI seals certificate on request.

All valves have a serial number. In case of non-standard valves, this number must be supplied if spare parts are ordered.

ORDERING CODES PS130													
Valve model	PS13	1	3	T	M	X	I	X	X	X	DI	15	E
PS130 – AISI 316L / 1.4404 diaphragm sensing pressure sustaining valve	PS13												
<b>Regulating range</b>													
0,2 to 1,5 bar		1											
0,3 to 3 bar		2											
2 to 8 bar		3											
0,2 to 8 bar (dome-loading) a)		A											
<b>Flow rate coefficient</b>													
Kvs 1,7		3											
Kvs 3 (not applicable to sizes 1/2" ASME BPE, DIN DN 10 and ISO DN 08)		6											
<b>Diaphragm</b>													
PTFE (Gylon)				T									
EPDM (non-standard)				E									
<b>Valve sealing</b>													
Metal to metal (non-standard)					M								
EPDM					E								
PTFE					T								
FPM / Viton (USP Class VI on request)					V								
<b>Leakage line connection</b>													
Without leakage line connection b)						X							
Leakage line connection – ISO 228 G 1/8"						N							
Leakage line connection – 1/8" NPT						C							
<b>Adjustment knob and top cap</b>													
Stainless steel adjustment knob							I						
Nylon adjustment knob							P						
Top cap (adjustment screw with cover)							T						
Dome-loading – ISO 228 G 1/4" b)							X						
Dome-loading – 1/4" NPT b)							C						
<b>Gauge connections</b>													
Without gauge connections								X					
Tri-clamp gauge connection on the left side (relative to flow direction) – upstream pressure								7					
Tri-clamp gauge connection on the right side (relative to flow direction) – upstream pressure								6					
Tri-clamp gauge connections on both sides – upstream pressure								5					
Threaded gauge connection on the left side (relative to flow direction) – upstream pressure – ISO 228 G 1/4"								4					
Threaded gauge connection on the right side (relative to flow direction) – upstream pressure – ISO 228 G 1/4"								3					
Threaded gauge connections on both sides – upstream pressure – ISO 228 G 1/4"								2					
Threaded gauge connection on the left side (relative to flow direction) – upstream pressure – 1/4" NPT								W					
Threaded gauge connection on the right side (relative to flow direction) – upstream pressure – 1/4" NPT								Y					
Threaded gauge connections on both sides – upstream pressure – 1/4" NPT								Z					
<b>Surface finish c)</b>													
Standard surface finish									X				
Mirror mechanical polished external surfaces (SF1)									P				
Electropolished internal wetted parts (SF5)									E				
<b>Special features</b>													
None										X			
Degreased for oxygen										O			
<b>Pipe connection</b>													
Clamp ferrule ASME BPE												D	
Clamp ferrule DIN (DIN 32676-A)												F	
Clamp ferrule ISO (DIN 32676-B)												E	
Tube weld (ETO) according to ASME BPE												DI	
Tube weld (ETO) according to DIN 11866-A (DIN 11850-2)												FI	
Tube weld (ETO) according to DIN 11866-B (ISO 1127)												EI	
<b>Size</b>													
DN 08													08
DN 10													10
1/2" or DN 15													15
3/4" or DN 20													20
1" or DN 25													25
<b>Special construction / Additional options</b>													
Full description or additional codes have to be added in case of non-standard combination													E

a) The loading control pressure can be up to a maximum of 1,2 bar above the required downstream pressure. b) Mandatory in case of dome-loading. c) Consult TIS.GIA – General information ADCAPure – for further details and other surface finish options.