

## SANITARY PRESSURE SUSTAINING VALVE PS161

### DESCRIPTION

The ADCAPure PS161 is a series of angle design direct acting diaphragm sensing pressure sustaining valves. These regulators, available with spring or dome-loading, are designed for use with clean steam, compressed air, water and other gases or liquids compatible with the construction materials and valve design.

### MAIN FEATURES

- Spring or dome-loaded.
- Non-rising adjustment knob.
- Compact design with clamped body.
- Available with low pressure diaphragm.
- FDA / USP Class VI compliant seals.
- Optimized internal designed to provide high flow capacities and minimum droop.
- Completely machined from bar stock material, no castings or forgings are used.

### STANDARD SURFACE FINISH

- Internal wetted parts:  $\leq 0,51$  micron Ra – SF1.
- External:  $\leq 0,76$  micron Ra – SF3.
- Other surface conditions see IS PV20.00 E – Technical information.
- Ultrasonic cleaning.

**OPTIONS:**

- Leakage line connection 1/8" (captured vent).
- Different soft sealings for liquids and gases.
- Gauge connection on body.
- Top cap (adjustment screw with cover).
- Dome-loaded version.

**USE:**

Clean steam, compressed air, water and other gases and liquids compatible with the construction.

**AVAILABLE MODELS:**

PS161.

**SIZES:** 1/2" to 2"; DN 15 to 50.

**REGULATING RANGES:**

0,8 to 1,5 bar; 1 to 3 bar; 1,5 to 5 bar.

**CONNECTIONS:** ASME BPE, DIN and ISO clamp ferrules or tube weld (ETO) ends.  
Others on request.

**PACKAGING:** Assembling and packaging in a clean room certified according to ISO 14644-1.  
The product is end capped and sealed with recyclable thermo-shrinkable plastic film, to avoid contamination.

**INSTALLATION:** Horizontal installation. Horizontal inlet and vertical outlet angle connection. See IMI.

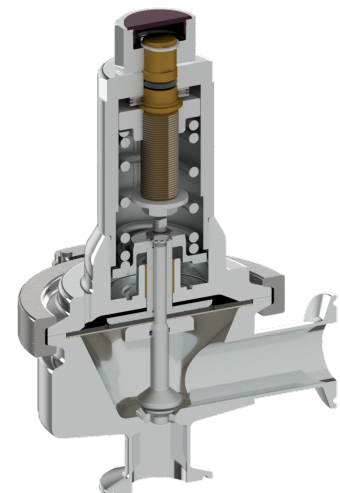

### LIMITING CONDITIONS

Valve model	PS161
Body design conditions	PN 16
Maximum upstream pressure	8 bar
Minimum upstream pressure	0,8 bar
Maximum operating temperature *	180 °C

\* With PTFE diaphragm and seals. Consult the manufacturer in case of other elastomer materials.

### CE MARKING – GROUP 2 (PED – European Directive)

PN 16	Category
1/2" to 2" – DN 15 to 50	SEP

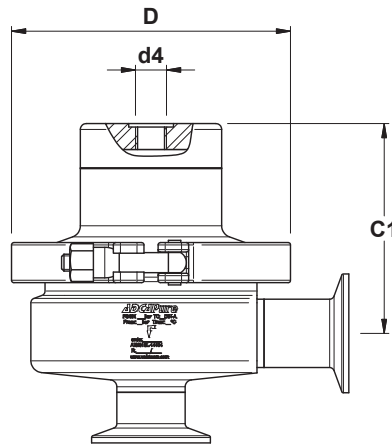
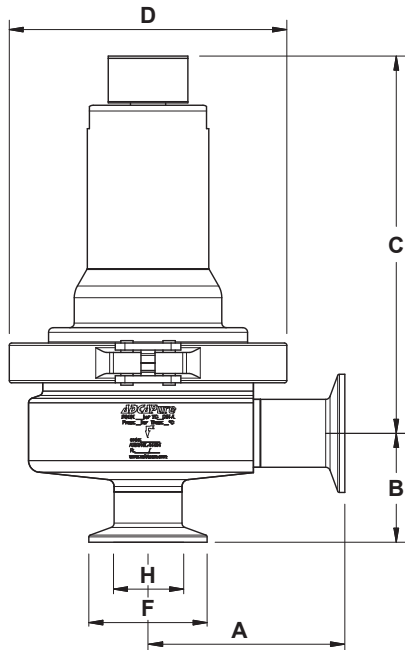

Optional dome-loaded version.

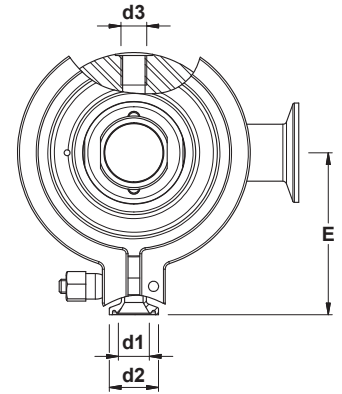

Optional pressure gauge connections.

**DIMENSIONS (mm) ASME BPE**

SIZE	A	B	C	C1	D	d1	d2	d3 *	d4 *	E	F	H	WGT. (kg)
1/2"	77	53	156	84	119	25	15,75	1/4"	1/4"	83	25	9,4	4,1
3/4"	77	56	160	88	119	25	15,75	1/4"	1/4"	83	25	15,75	4,4
1"	77	52	163	91	119	25	15,75	1/4"	1/4"	83	50,5	22,1	4,6
1 1/2"	85	61	204	124	134	25	15,75	1/4"	1/4"	96	50,5	34,8	8
2"	85	67	207	127	134	25	15,75	1/4"	1/4"	96	64	47,5	8,6

**DIMENSIONS (mm) DIN**

SIZE	A	B	C	C1	D	d1	d2	d3 *	d4 *	E	F	H	WGT. (kg)
DN 15	77	45	160	88	119	25	15,75	1/4"	1/4"	83	34	16	4,4
DN 20	77	40	158	86	119	25	15,75	1/4"	1/4"	83	34	20	4,3
DN 25	84	47	161	89	119	25	15,75	1/4"	1/4"	83	50,5	26	4,6
DN 32	84	50	163	91	119	25	15,75	1/4"	1/4"	83	50,5	32	4,8
DN 40	93	69	202	122	134	25	15,75	1/4"	1/4"	96	50,5	38	8
DN 50	93	75	206	126	134	25	15,75	1/4"	1/4"	96	64	50	8,6

Remarks: Clamp ferrules according to DIN 32676-A; Tube weld (ETO) according to DIN 11866-A (DIN 11850-2).

**DIMENSIONS (mm) ISO**

SIZE	A	B	C	C1	D	d1	d2	d3 *	d4 *	E	F	H	WGT. (kg)
DN 15	84	43	159	87	119	25	15,75	1/4"	1/4"	83	50,5	18,1	4,4
DN 20	84	46	162	90	119	25	15,75	1/4"	1/4"	83	50,5	23,7	4,6
DN 25	84	49	164	92	119	25	15,75	1/4"	1/4"	83	50,5	29,7	4,8
DN 32	93	70	202	122	134	25	15,75	1/4"	1/4"	96	64	38,4	8,2
DN 40	93	75	206	126	134	25	15,75	1/4"	1/4"	96	64	44,3	8,8

Remarks: Clamp ferrules according to DIN 32676-B; Tube weld (ETO) according to DIN 11866-B (ISO 1127).

\* As standard, connections d3 and d4 are female threaded ISO 7 Rp.

**FLOW RATE COEFFICIENTS (m³/h)**

SIZE	ASME BPE					DIN						ISO				
	1/2"	3/4"	1"	1 1/2"	2"	DN 15	DN 20	DN 25	DN 32	DN 40	DN 50	DN 15	DN 20	DN 25	DN 32	DN 40
<b>Kvs</b>	1,6	3,2	5,3	13,0	19,8	2,8	3,2	5,3	5,3	13,0	19,8	2,8	5,3	5,3	13,0	13,0

**MATERIALS**

POS. N°	DESIGNATION	MATERIAL
1	Valve body	AISI 316L / 1.4404
2	Cover	AISI 316L / 1.4404
3	Intermediate flange	AISI 316L / 1.4404
3A	Clamp	AISI 316 / 1.4401
4	* Valve stem	AISI 316L / 1.4404
5	* Soft plug	** EPDM; PTFE; FPM
6	* Valve plug	AISI 316L / 1.4404
7	* Upper diaphragm	EPDM
8	* Lower diaphragm	PTFE (Gylon)
9	Diaphragm plate	AISI 316L / 1.4404
10	* O-ring	EPDM
11	Diaphragm plate	AISI 316L / 1.4404
12	Stem guide	AISI 316L / 1.4404
12A	Plain bearing	Bronze
13	Spring plate	AISI 316L / 1.4404
14	Nut	AISI 304 / 1.4301
15	Washer	AISI 304 / 1.4301
16	* Adjustment spring	AISI 302 / 1.4300
17	Top spring plate	AISI 316L / 1.4404
18	Retaining washer	Stainless steel A2-70
19	Adjustment nut	AISI 316L / 1.4404
20	Adjustment screw	Brass
21	O-ring	NBR
22	Bearing	Corrosion resistant steel
23	Ext. bowed shaft ring	Stainless steel
24	Cover nut	Plastic
25	* O-ring	NBR

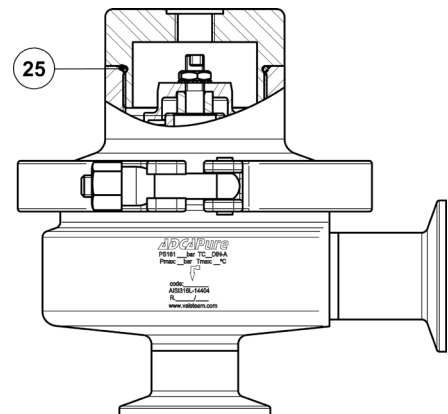
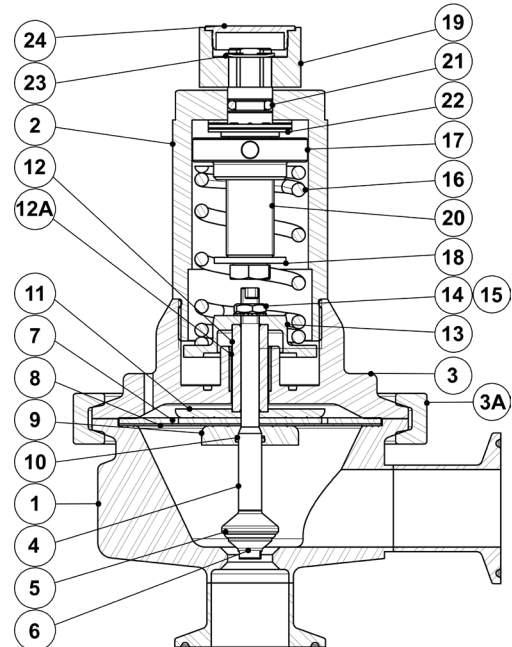

*Dome-loaded top*

\* Available spare parts; \*\* Others according to fluid.

Remarks: FDA / USP Class VI seals certificate on request.

All valves have a serial number. In case of non-standard valves, this number must be supplied if spare parts are ordered.

**OPTIONS**

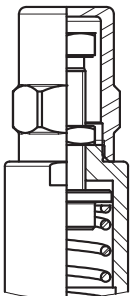
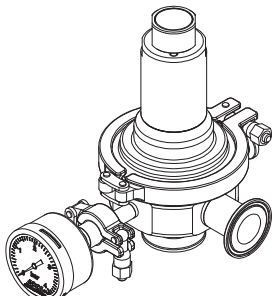
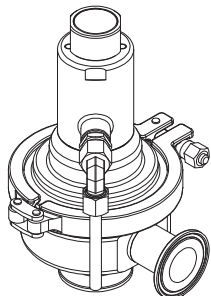
ADJUSTMENT SCREW WITH TOP CAP	PRESSURE GAUGE CONNECTION	LEAKAGE LINE CONNECTION
		

ORDERING CODES PS161

Valve model	PS16	1	4	1	T	M	I	X	X	X	DI	15	E
PS161 – AISI 316L / 1.4404 diaphragm sensing pressure sustaining valve	PS16												
<b>Valve series</b>													
Series 1		1											
<b>Regulating range</b>													
0,8 to 1,5 bar			4										
1 to 3 bar			5										
1,5 to 5 bar			6										
0,8 to 5 bar (dome-loaded) a)			A										
<b>Flow rate coefficient</b>													
Kvs 1,3 (only applicable to ASME BPE 1/2" size)			1										
Kvs 2,8 (applicable to sizes DIN DN 15 and ISO DN 15)			2										
Kvs 3,2 (applicable to sizes ASME BPE 3/4" and DIN DN 20)			3										
Kvs 5,3 (applicable to sizes ASME BPE 1", DIN DN 25 to DN 32 and ISO DN 20 to DN 25)			4										
Kvs 13,0 (applicable to sizes ASME BPE 1 1/2", DIN DN 40 and ISO DN 32 to DN 40)			6										
Kvs 19,8 (applicable to sizes ASME BPE 2" and DIN DN 50)			8										
<b>Diaphragm</b>													
PTFE (Gylon)					T								
EPDM (non-standard)					E								
<b>Seat material b)</b>													
Metal to metal (non-standard, except in ASME BPE 1/2" size)						M							
EPDM						E							
PTFE						T							
FPM / Viton (FDA approval only)						V							
<b>Adjustment knob, top cap and captured vent</b>													
Stainless steel adjustment knob							I						
Top cap (adjustment screw with cover)							T						
Stainless steel adjustment knob w/ diaphragm cover leakage connection in case of diaphragm failure							L						
Top cap (adjustment screw with cover) w/ diaphragm cover leakage connection in case of diaphragm failure							U						
Dome-loaded top c)							X						
<b>Gauge port options</b>													
Without gauge ports								X					
Tri-clamp gauge port on the left side (rel. to the flow direction) – downstream pressure								7					
Tri-clamp gauge port on the right side (rel. to the flow direction) – downstream pressure								6					
Tri-clamp gauge port on both sides – downstream pressure								5					
Threaded gauge port on the left side (rel. to the flow direction) – downstream pressure – ISO 7 Rp 1/4"								4					
Threaded gauge port on the right side (rel. to the flow direction) – downstream pressure – ISO 7 Rp 1/4"								3					
Threaded gauge port on both sides – downstream pressure – ISO 7 Rp 1/4"								2					
Threaded gauge port on the left side (rel. to the flow direction) – downstream pressure – 1/4" NPT								W					
Threaded gauge port on the right side (rel. to the flow direction) – downstream pressure – 1/4" NPT								Y					
Threaded gauge port on both sides – downstream pressure – 1/4" NPT								Z					
<b>Surface finish d)</b>													
Standard surface finish									X				
Mirror mechanical polished external surfaces (SF1)									P				
Electropolished internal wetted parts (SF5)									E				
<b>Special features</b>													
None										X			
Degreased for oxygen										O			
<b>Pipe connections</b>													
Clamp ferrule ASME BPE												D	
Clamp ferrule DIN (DIN 32676-A)												F	
Clamp ferrule ISO (DIN 32676-B)												E	
Tube weld (ETO) according to ASME BPE												DI	
Tube weld (ETO) according to DIN 11866-A (DIN 11850-2)												FI	
Tube weld (ETO) according to DIN 11866-B (ISO 1127)												EI	
<b>Size</b>													
1/2" or DN 15												15	
3/4" or DN 20												20	
1" or DN 25												25	
DN 32												32	
1 1/2" or DN 40												40	
2" or DN 50												50	
<b>Special valves / Extras</b>													
Full description or additional codes have to be added in case of a non-standard combination													E

a) The loading control pressure can be up to a maximum of 0,2 bar above the required upstream pressure; b) ASME BPE 1/2" size is only available with metal to metal sealing; c) Must be chosen in case of dome-loaded version; d) Consult IS PV20.00 – Technical information – for further details and other surface finish options.