

SPK Flat Sight Glass with TC Connection

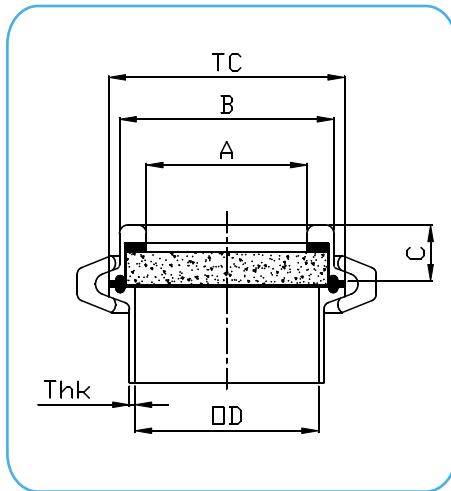

CODE	SIZE	ØTC mm	OD x Thk mm	A mm	B mm	C mm	Ferrule Length mm	Glass mm	
								OD	Thk
SPK-100-XG-71A	1"	50.5	25.4 x 1.65	22.5	44	18	28.6	38.5	10
SPK-150-XG-71A	1 ½"	50.5	38.1 x 1.65	28	44	18	28.6	38.5	10
SPK-200-XG-71A	2"	64	50.8 x 1.65	41	56	18	28.6	51.5	10
SPK-250-XG-71A	2 ½"	77.5	63.5 x 1.65	54.5	70	18	28.6	65	10
SPK-300-XG-71A	3"	91	76.2 x 1.65	67.5	82.7	18	28.6	78	10
SPK-400-XG-71A	4"	119	101.6 x 2.10	84	110	23	28.6	105	15

Technical Information:

Tri-Clamp Connections: according to ASME BPE

Cover Material: AISI 316L – 1.4404

Ferrule Material: AISI 316L – 1.4404

Clamp Material: AISI 304 – 1.4301

Glass Material: Borosilicate Tempered

Clamp Gasket Material: Silicone (X) Optional: EPDM (E), FKM (V), PTFE (G)

Glass Gasket Material: PTFE (G) Optional: Silicone (X)

Internal Surface Finish: Ra ≤ 0.5µm code 71 e.g.: SPK-100-XG-71A

Specifications:

Max Working Pressure: 6 barg

Max Working Temperature: 150°C

Marking: Each SPK Sight Glass is marked with Heat No. for full lot traceability.

Advantages :

- Clear process visibility
- Fast and simple installation and maintenance
- Suitable for sterile applications
- Extremely compact design with large viewing area
- No product entrapment
- Sterilizable – Autoclavable