

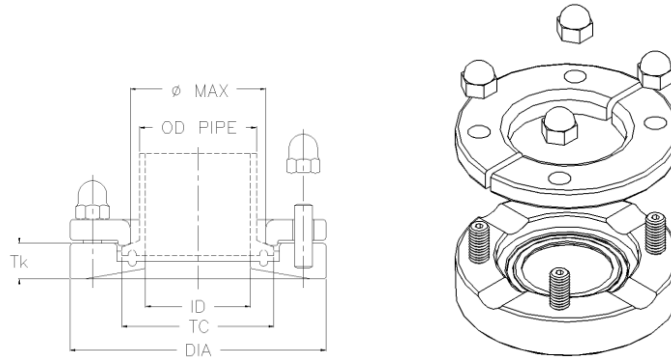

Sanitary
flow
equipment



TK-Connect pipe standard ASTM A270 Clamp Standard ASME-BPE, BS 4825



dimensions table

CODE	DN	TC	ID	OD pipe	φ max	DIA	Tk std	Tk 1	Tk 2	Tk 3	Bolts
TKC-AG...-12A	1/2"	25,0	9,4	12,7	20,0	55,0	15,0	25,0	38,0	51,0	4 x M6
TKC-AH...-12A	3/4"	25,0	15,75	19,05	20,0	55,0	15,0	25,0	38,0	51,0	4 x M6
TKC-AJ...-12A	1"	50,4	22,1	25,4	45,0	85,0	17,0	25,0	38,0	51,0	4 x M8
TKC-AM...-12A	1 1/2"	50,4	34,8	38,1	45,0	85,0	17,0	25,0	38,0	51,0	4 x M8
TKC-AN...-12A	2"	64,0	47,5	50,8	57,0	100,0	17,0	25,0	38,0	51,0	4 x M8
TKC-AO...-12A	2 1/2"	77,5	60,2	63,5	71,0	112,0	17,0	25,0	38,0	51,0	4 x M8
TKC-AP...-12A	3"	91,0	72,9	76,2	85,0	130,0	20,0	25,0	38,0	51,0	6 x M8
TKC-AR...-12A	4"	119,0	97,6	101,6	113,0	170,0	20,0	25,0	38,0	51,0	8 x M8
TKC-AV...-12A	6"	166,7	146,8	152,4	161,0	220,0	30,0	0,0	0,0	0,0	8 x M10
TKC-AW...-12A	8"	217,5	197,66	203,2	210,0	290,0	35,0	0,0	0,0	0,0	8 x M10
TKC-AX...-12A	10"	268,5	248,66	254,0	260,0	350,0	45,0	0,0	0,0	0,0	12 x M10

Available thickness : TK Standard normally at stock, TK1 = 25,0mm TK2 = 38,0mm TK3 = 51,0mm (different thickness available on specific request)
In case of order please specify the thickness you need

Specifications

- Standards :** designed according to PED 97/23/CE directive for Europe, ASME VIII Div.2 for US and F.E.M. (Finite Element Method) calculated, approved and certified by notified body (except the red sizes market)
- Design Pressure :** -1 bar to 7 bar g (-14,5 psi to 101,5 psi)
Note : The applied gasket (not included) may have different design temperature and/or pressure limits than the TK. The weakest component in the assembled product determines the maximum design temperature and pressure limits.
- Design Temperature :** -80°C to 200°C (-112°F to 392°F)
- Material :**
welding flange ASTM A 479 / ASTM A 182 316L-1.4404 on request 1.4435
locking ring ASTM A 479 / ASTM A 182 - 316L-1.4404
bolts ASTM A 193 B8 – 304-1.4301
nut ASTM A 194 8 – 304-1.4301
- Surface Finish :** Product contact surface are finished to Ra<0,6 μm or better
- Marking :** Each TK-Connection is market with Heat No. for full lot traceability

In the interests of development and improvement of the product, we reserve the right to change the specifications without prior notice.