



Sanitary
flow
equipment



VSS Standards Dimensions and torque values

MANUAL HANDLE

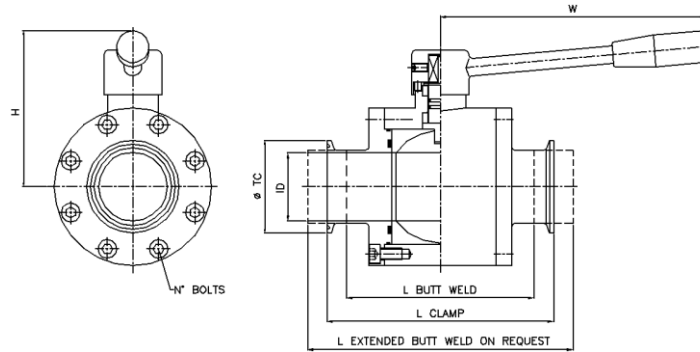

CODE	INCH	DN	ØTC	ID	LBW	LTC	W	H	Kv	Kg
VSS-050AGAG-..MSI-11A	1/2"	15	25	9,4	102	106	95	50	4,68	0,900
VSS-075AHAH-..MSI-11A	3/4"	20	25	15,7	102	106	95	50	10,2	0,850
VSS-100AJAJ-..MSI-11A	1"	25	50,4	22,1	120	120	155	75	24,6	2,500
VSS-150AMAM-..MSI-11A	1" 1/2	40	50,4	34,8	135	135	185	85	48,3	3,500
VSS-200ANAN-..MSI-11A	2"	50	64	47,5	147	147	185	85	77,8	5,800
VSS-250AOAO-..MSI-11A	2" 1/2	65	77,4	60,2	160	160	240	105	87,0	6,900
VSS-300APAP-..MSI-11A	3"	80	90	72,9	180	180	240	115	105,6	14,800
VSS-400ARAR-..MSI-11A	4"	100	118,8	97,6	215	215	240	150	129,0	24,500

Kv in mc/h = Kv value with fully open ball; fluids: water, ambient temperature 20°C

L overall length =LBW butt weld (code BB) LTC clamped (code AA)

special extended tube for orbital welding available on request

ISO 5211 MOUNTING PAD FOR PNEUMATIC ACTUATOR

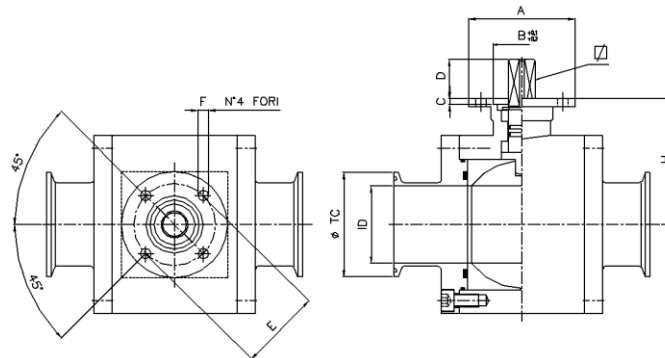

CODE	A	B	C	D	E	F	ISO	□	Nm	H
Actuator type	SR-DA	SR-DA	SR-DA	SR-DA	SR-DA	SR-DA	SR-DA	SR-DA	@	
VSS-050AGAG-..W-11A	Ø45	25	2,5	9,5	36	5,5	F03	9	15	38,5
VSS-075AHAH-..W-11A	Ø45	25	2,5	9,5	36	5,5	F03	9	15	38,5
VSS-100AJAJ-..W-11A	Ø55-45	30-25	2,5	11,5-10	42-50	5,5-6,5	F04-F05	11-9	30	58,5
VSS-150AMAM-..W-11A	Ø65	35	3,5	14,5-12	50	6,5	F05	14-11	60	67
VSS-200ANAN-..W-11A	Ø65	35	3,5	14,5	50	6,5	F05	17-14	120	77
VSS-250AOAO-..W-11A	Ø85	35	3,5	19-14,5	70	8,5	F07	22-17	180	83,5
VSS-300APAP-..W-11A	Ø85	35	3,5	19-14,5	70	8,5	F07	22-17	240	97
VSS-400ARAR-..W-11A	Ø150-120	85-55	3,5	25-18	125-102	13-11	F12-F10	27-22	480	126

Pneumatic actuator type : SR = Simple Effect, spring return DA= Double Effect, air to close

@ Maximum break-out torque in Nm.

In the interests of development and improvement of the product, we reserve the right to change the specifications without prior notice.