

3-A SYMBOL NOTICE: This rupture disc is 3-A certified. 3-A is only valid when installed in compliance with applicable 3-A Standards and 3-A Accepted Practices, including 3-A Accepted Practice code number 606-04, E5.8 requiring the installation to be self-draining. (Exception: white EPDM gasket is not 3-A approved). Rupture discs using PTFE or SST filled PTFE gaskets require bolted clamps 13MHP in order to comply with the 3-A leak test requirement.



This rupture disc has non-bonded gaskets and is designated as "One Time Installation" and the design is easily cleaned by CIP and not intended for removal and reinstallation for compliance with 3-A.

WARNING:

- Read these instructions carefully and completely before attempting to unpack, install or service the rupture disc.
- Do not vent a rupture disc assembly to an area where it would endanger personnel.
- Install the rupture disc assembly in such a way that equipment in the area will not prevent rupture disc from opening or be damaged by system discharge.
- The SR-H, SHX, AD-H TC, Axius SC, and AGT-SC rupture discs are designed for clean in place applications, however be sure that no brush, jet stream or any other cleaning mechanism makes contact with the disc.
- Flow arrows on rupture disc tag must point in the same direction as process flow.
- A baffle plate on the outlet end of vent piping does NOT necessarily prevent potentially dangerous discharge.
- Install the enclosed DANGER sign in a conspicuous location near the zone of potential danger.
- Confirm the ferrule and clamp pressure and temperature rating prior to installing Fike rupture disc.
- Axius SC not suitable for liquid systems in 1" and 1.5" sizes at burst pressures less than 65 psig and an inlet piping length greater than 10 inches.

Ferrule Standards:

The Fike SR-H, SHX, AD-H TC, Axius SC, and AGT-SC rupture discs are designed for use in standard sanitary ferrules and clamps. Note that there are a variety of sanitary ferrule standards used in industry, including but not limited to Tri-Clover, DIN 32676, ISO 2852, NovAseptic (NA) etc. While appearing very similar, the ferrules are different dimensionally and the rupture disc is not generally interchangeable between ferrule standards.

Clamp Types:

The Fike rupture discs are designed to be compatible with the most common 13MHHM clamp, A8647-100-X clamp and NovAseptic (NA Connect) flanges. The A8647-100-X clamp is a modified 13MHP clamp that allows clearance for the rupture disc tag extension.

- CAUTION - Using clamps other than the 13MHHM clamp or A8647-100-X clamp may result in the clamp bottoming out on the tag extension prior to achieving sufficient clamping force to seal the rupture disc.
- All sizes of PTFE and SST Filled PTFE gaskets require the A8647-100-X bolted clamp, high pressure clamp for 3-A leak tight compliance. 1" Size is not compatible with 13MHP and thus not 3-A compliant with these gaskets.

- Exception: PTFE and SST Filled PTFE gaskets can be used with the 13MHHM wingnut clamps or NA Connect when 3-A compliance is not required, and the customer has acceptable experience with these gasket materials and clamps.
- The 1" size Axius SC is currently only validated for installation using the 13MHHM clamp and NA Connect.



13MHHM Clamp



Fike A8647-100 modified 13MHP Clamp



NovAseptic NA Connect Flange Flush Mount

Clamp Photos

INSPECTION/PREPARATION

Except where noted, rupture disc applies to both the metal assembly and soft gasket.

A. NEW RUPTURE DISCS

WARNING: Always handle the rupture disc with extreme caution. Nicks, dents, scratches or foreign material may result in leakage or affect the burst pressure. Read the rupture disc tag completely before installing to confirm that the size and type are correct for your system.

1. Carefully remove the rupture disc from its packing container.
2. Inspect the rupture disc for damage. Look for nicks or cuts in the gasket or dents in the dome of the rupture disc.
3. Unless otherwise specified, the rupture disc has been cleaned with a water soluble detergent and is ready for installation. However, the rupture disc may be cleaned by dipping in alcohol, using slight agitation, and air dried.
4. The rupture disc is designed to be easily cleaned by CIP.

B. MAINTAINING EXISTING RUPTURE DISCS

The rupture disc can be removed for inspection. As a 3-A "One Time Installation" it is not intended for reinstallation. Install a new replacement disc.

C. FERRULE INSTALLATION WITH 13MHHM CLAMP

See Figure 1

WARNING: Before attempting to install the rupture disc, confirm that the rupture disc size matches the ferrule size.

1. Verify the process flow direction.
2. Verify and ensure that all ferrule and clamp working surfaces are clean, dry, and free of nicks, dents, gouges, and galling.
3. Silicone, Viton™, or EPDM Gaskets – inspect gasket position and ensure that gasket ID is centered on dome of disc, then place the rupture disc into the ferrules with the flow arrow on the rupture disc tag pointing in the same direction as the desired flow. Go to step 5.



Figure 1

4. PTFE and SST filled PTFE gaskets – carefully place both of the gasket halves on the rupture disc so that they interlock around the outside diameter of the disc and so that the rupture disc tag extends through the notches in the gasket halves. Place the assembly into the ferrules with the flow arrow on the rupture disc tag pointing in the same direction as the desired flow.
5. Install the clamp around the ferrules so that the gap between the two clamp halves is centered on the rupture disc tag.
6. Hand-tighten the wing nut until the clamp is fully engaged with the ferrules and the rupture disc is securely in position, approximately 25 in-lbs.

D. FERRULE INSTALLATION WITH FIKE CLAMP

A8647-100-X – See Figure 2

WARNING: Before attempting to install the rupture disc, confirm that the rupture disc size matches the ferrule size.

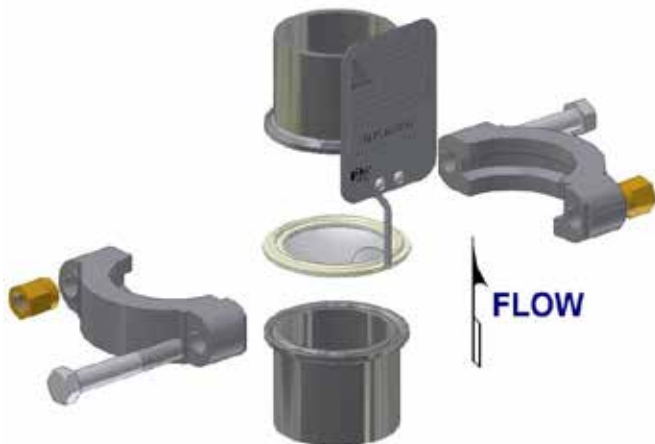

Figure 2

1. Verify the process flow direction.
2. Verify and ensure that all ferrule and clamp working surfaces are clean, dry, and free of nicks, dents, gouges, and galling.
3. Silicone, Viton™, or EPDM gaskets – inspect gasket position and ensure that gasket ID is centered on dome of disc, then place the rupture disc in the ferrules with the flow arrow on the rupture disc tag pointing in the same direction as the desired flow. Go to step 5.
4. PTFE and SST filled PTFE gaskets – carefully place both of the gasket halves on the rupture disc so they interlock around the outside diameter of the disc so that the rupture disc tag extends through the notches in the gasket halves. Place the assembly into the ferrules with the flow arrow on the rupture disc tag pointing in the same direction as the desired flow.

5. Install the A8647-100-X clamp around the ferrules and orient so the rupture disc tag fits between the clamp halves at the relief cut out.
6. Tighten the nuts evenly to approximately 150 in-lb for the 1 1/2" clamp and 240 in-lb for the 2", 3" and 4" clamp.

E. NOVASEPTIC (NA CONNECT™) INSTALLATION - See Figure 3

WARNING: Before attempting to install the rupture disc, confirm that the rupture disc size matches the ferrule size.



Figure 3

1. Verify the process flow direction.
2. Verify and ensure that all ferrule and clamp working surfaces are clean, dry, and free of nicks, dents, gouges, and galling.
3. Silicone, Viton™, or EPDM Gaskets – inspect gasket position and ensure that gasket ID is centered on dome of disc, then place the rupture disc between the female seat and the outlet ferrule with the flow arrow on the rupture disc tag pointing in the same direction as the desired flow.
4. PTFE and SST filled PTFE gaskets – carefully place both of the gasket halves on the rupture disc so that the rupture disc tag extends through the notches in the gasket halves. Place the assembly into the NA Connect.
5. Install the split flanges on the ferrule and orient so the rupture disc tag fits between the flanges.
6. Tighten the nuts evenly to approximately 25 in-lb.

F. ALL INSTALLATIONS

WARNING: Double check the orientation of the rupture disc. Verify flow arrows on the disc tags are pointed in the same direction as the desired flow.

Under normal operating conditions, the rupture disc should be replaced annually. Severe operating conditions may require that the rupture disc be replaced more often.

NOTE: Rupture disc specifications and year of manufacture can be found on the rupture disc tag.

G. INTEGRATED BURST INDICATOR

WARNING: Read these instructions carefully and completely before attempting to unpack, install or service the indicator.

- Specific attention must be paid to the circuit. Special care must be taken to avoid applying any force to the circuit or Teflon actuator.

CERTIFICATION FOR INTEGRATED BURST INDICATOR

Standards:	ATEX 2014/34/EU
IEC 60079-0	EN 60079-0 EN 60079-11
IEC 60079-11	UK SI 2016 No. 1107

Note - see fike.com Approvals for current year references for each Standard.

Protection marking:		Certificates:	
II 1G Ex ia IIB T4 Ga	UK CA Ex	IECEX TPS 21.0007X	For BC2(LP), BCH(LP) only
II 1D Ex ia IIIC T135°C Da Ta -40°C to 80°C		TÜV IT 18 ATEX 057 X TÜV SUD 23 UKEX 000033 X	
II 1G Ex ia IIB T6 Ga	UK CA Ex	IECEX TPS 21.0007X	
II 1D Ex ia IIIC T85°C Da Ta -40°C to 70°C		TÜV IT 18 ATEX 057 X TÜV SUD 23 UKEX 000033 X	

Explanation of Markings

II	1G	Ex	ia	IIB	T4	Ga		
	II	1G	Ex	ia	IIB	T6	Ga	
		II	1D	Ex	ia	IIIC	T135°C	Da
			II	1D	Ex	ia	IIIC	T85°C
II	II	II	II					Product Group
1G	1G	1D	1D					Product Category
Ex	Ex	Ex	Ex					Explosion Protection Symbol
ia	ia	ia	ia					Intrinsic Safety
		IIIC	IIIC					Explosion Gp; Dust & Fibers
IIB	IIB							Explosion Gp: Ethylene and other gases
T4	T6	T135°C	T85°C					Max Surface Temperature
Ga	Ga	Da	Da					Equipment Protection Level (EPL)
		Ta -40°C to 70°C						Ambient Temperature
		Ta -40°C to 80°C						Ambient Temperature

For use under special conditions; intrinsic safety when connected through a listed safety barrier.

The “Ambient” temperature rating (Ta) for the burst indicator is defined on the Fike IECEX Certificate and refers to the Surrounding Area per ATEX 2014/34/EU Guidelines (2nd ed. December 2017) Section 143.

CSA Standards:

CAN/CSA C22.2 No. 60079-0:19 & 60079-11:14 (R2018)
CAN/CSA-C22.2 No. 61010-1-12
ANSI/UL 61010-1 (3rd Ed) & 60079-11-2014 (6th Ed)
ANSI/UL 60079-0-2020 UL 913 (8th Ed.)

CSA Marking

Class I, Division 1, Groups C and D:
Ex ia IIB T6/T4 Ga
Class I, Zone 0 AEx ia IIB T6/T4 Ga
Class II, Groups E, F and G; Class III
Ex ia IIIC T85°C/T135°C Da
Zone 20 AEx ia IIIC T85°C/T135°C Da
(where AEx refers to “America”)
Where Temperature class is:

T4/ T135°C for an ambient temperature from -40°C to +80°C
T6/ T85°C for an ambient temperature from -40°C to +70°C



INTEGRATED BURST INDICATOR WIRING

The indicator should be wired per the wiring diagram illustrated in Figure 4. Install in accordance with all applicable local and national codes (in Canada, Canadian Electric Code, Part 1).

Fike lead cable D3513-115-X is ordered separately.

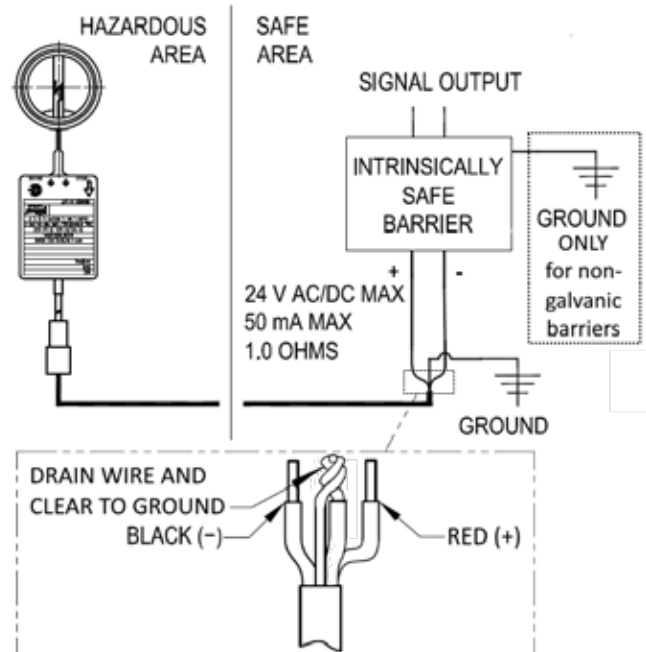

Figure 4 -- Integrated burst indicator wiring diagram

NOTE: The burst indicator is intrinsically safe for Class I, Division 1, Groups C & D, and Class II, Groups E, F, & G, and Class III when connected through a listed safety barrier (CSA, FM, UL) with entity parameters:

$U_i = 28.4 \text{ V}$, $P_i = 0.615 \text{ W}$, $I_i = 93 \text{ mA}$, $L_i = 5.6 \text{ } \mu\text{H}$, $C_i = 1.8 \text{ nF}$.

NOTE: For hazardous locations, barriers must be CSA, FM, or UL certified and must be installed in accordance with barrier manufacturer’s instructions. Barrier parameters are as follows: 28 V (max), 300 ohm (min).

NOTE: For the Low Pressure (LP) integrated Burst Indicators the safety barrier shall be galvanically isolated.

Fike CSA approved intrinsically safe barriers:

02-16086 Safety Barrier (no galvanic isolation)

Galvanic Isolated intrinsically safe barriers:

02-9884 Switching Repeater

02-12110 Isolating Switch Amplifier

02-13775 Isolating Switch Amplifier

Integrated Burst Indicators are rated for intrinsic safety in dust explosion risk environments up to 135°C (275°F) for IECEX compliance. However, the rupture disc may have a higher burst temperature for non-dust applications.

NOTE: Rupture disc specifications can be found on the rupture disc tag. When equipped with an integrated burst indicator, a tie strap is recommended to hold the wiring secure to the piping, as shown in Figure 5.

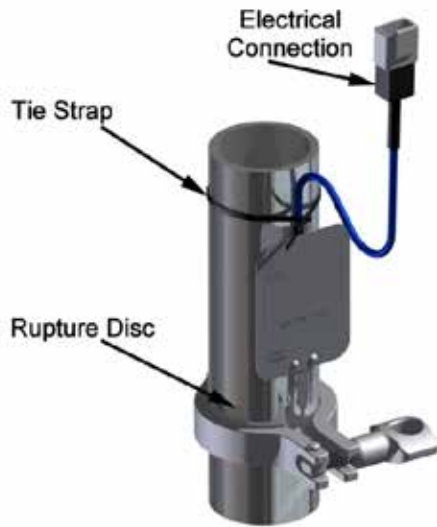

Figure 5

NOTE: See Figure 6 for a representation of the burst indicator installed on a rupture disc.

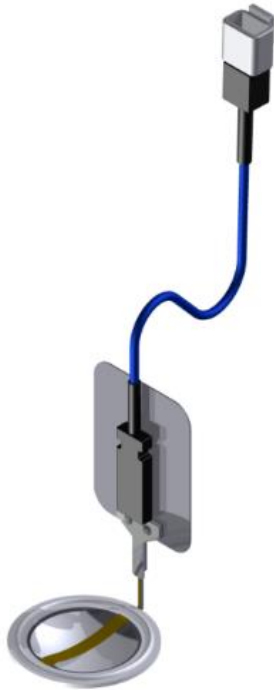

Figure 6