

METAGLAS® Sight glass Discs for Aseptic Screwed Pipe Connection DIN 11864-1 for Mounting Luminaires USL33, BKVLR-A

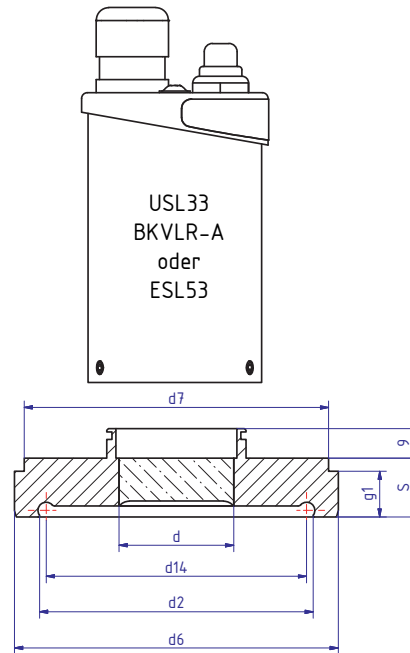

Applications

- Aseptic screwed pipe connection
DIN 11864-1

Material certificates

- Certificate of Conformity
EN 10204 – 3.1 or 3.2

Operating conditions for sight glass

Ring materials	Temperature (TS)
1.4462	-30°C bis +280°C
2.4602	-60°C bis +300°C
2.4605	-60°C bis +300°C
2.4610	-60°C bis +300°C

Technical data Manufactured and tested to:

- Directive for pressure equipment 2014/68/EU, Module H (DIN/EN/ISO 9001)
- AD2000 Standards W0/TRD 100
- Sight glass fused to metal conforming to DIN 7079
- Materials to VdTÜV specifications and the DIN/EN designated standards
- Glass: Borosilicate to DIN 7080 / DIN 7079

Advantages

- Security against total failure
- Sterile
- Long operating time
- Easy, instruction free installation
- Suitable for CIP and SIP cleaning

For further technical information see data sheets USL33/ ESL53 or BKVLR-A

Nominal size DN			max. operating pressure [bar]	d6	d	d14	d7	d2	g1	S	O –Ring
Series A DIN 11850	Series B ISO 1127	Series C ISO 2037 BS 4825									
–	–	1½"	25	54,9	28	41,45	48	45,46	10	14	37 x 5
40	–	–	25	54,9	28	44,65	55	44,56	10	14	40 x 5
–	42,4	–	25	54,9	28	45,05	55	49,06	10	14	40,5 x 5
–	48,3	–	25	66,9	34	50,95	61	54,96	11	15	46,5 x 5
–	–	2"	25	66,9	34	54,45	61	58,46	11	15	50 x 5
50	–	–	25	66,9	34	56,65	61	60,66	11	15	52 x 5
–	60,3	–	16	84,9	34	62,95	79	66,96	12	15	58,5 x 5
–	–	2½"	16	84,9	34	66,85	79	70,86	12	15	62 x 5
65	–	–	16	84,9	34	72,65	79	76,66	12	15	68 x 5
80	–	–	16	98,9	35	87,65	93	91,66	14	18	83 x 5