

# NPT ADAPTORS MALE METRIC

## NPT Adaptors Male Metric

NPT adaptors are available as either male or female and are supplied with a NPT thread. All threaded adaptors are manufactured from solid 316L bar stock. This offers both excellent material properties and guarantees good controllable surface finishes.

The flanged clamping side of the NPT adaptors are dimensioned and manufactured to 'mate up' directly with corresponding ferrules to BS4825, ISO & DN32676 standards, completing the clean crevice free transition between threaded pipe and the Tri-Clamp union.



## Technical information

Sizes	see table
Connections	Tri-Clamp
Material	1.4404 (316L)
Finishes	SF1
Certificates	3.1 - Solid Bar

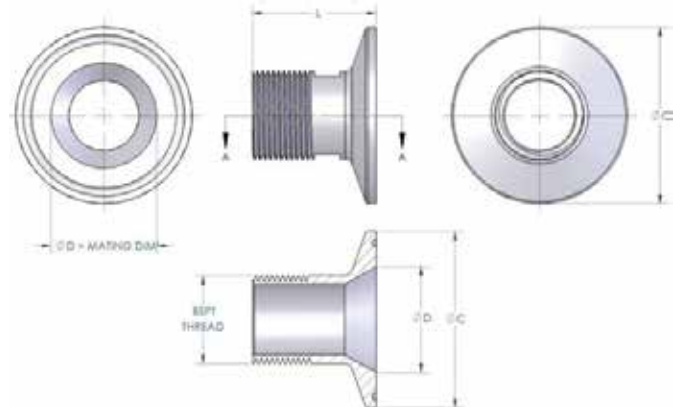

FERRULE	THREAD	Flange ØC	Mating ØD	Length L *	Mass (kg)
DN10	1/4"	34.0	10.0	30	0.05
	3/8"	34.0	10.0	30	0.06
	1/2"	34.0	10.0	30	0.07
	3/4"	34.0	10.0	30	0.08
DN15	1/4"	34.0	16.0	30	0.05
	3/8"	34.0	16.0	30	0.06
	1/2"	34.0	16.0	30	0.07
	3/4"	34.0	16.0	30	0.08
DN20	1/4"	34.0	20.0	30	0.05
	3/8"	34.0	20.0	30	0.05
	1/2"	34.0	20.0	30	0.06
	3/4"	34.0	20.0	30	0.07

\* These dimensions are indicative, actual sizes may vary.