

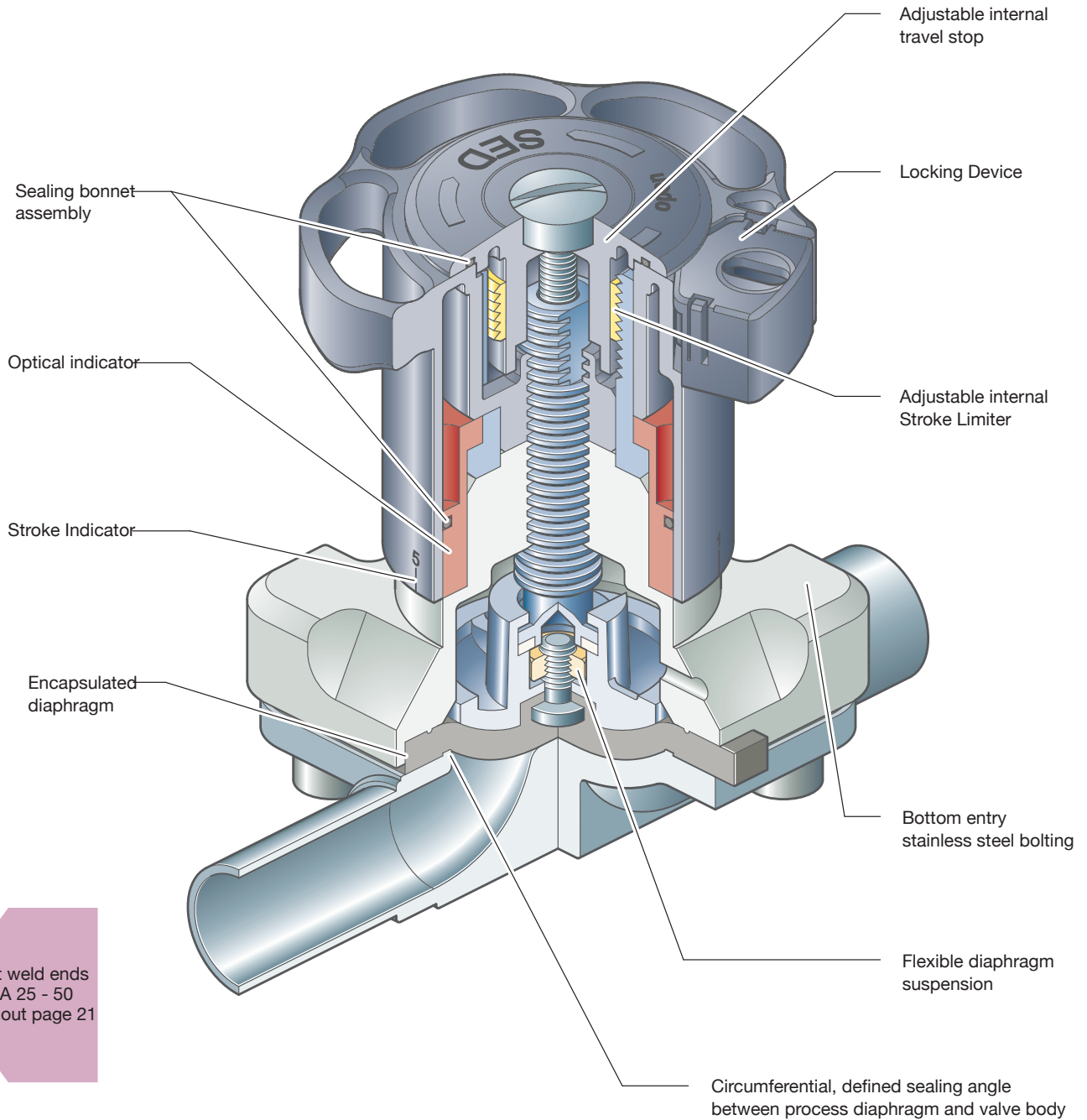

KMA 905

Manual Valve DN 15 - 50 mm (3/4" - 2 1/2")



Butt weld ends
MA 25 - 50
Fold out page 21

Manual Valve DN 15 - 50 mm (3/4" - 2 1/2")



KMA 905 , S11

Features

- **Stainless steel bonnet and plastic hand wheel**
- Manual diaphragm Valve with plastic hand wheel is suitable for a limited number of cycles of autoclaving.
- Rising hand wheel with optical indicator and stroke indicator
- Sealed bonnet
- Internal travel stop
- Locking device
- CDSA sealing concept, see page 32
- Flexible diaphragm suspension
- Encapsulated diaphragm

Optional

- Adjustable internal stroke limiter
- U-Lock for hand wheel
- Assembly of proximity switches

Technical Data

Control function:	Manually operated
Max. working pressure:	10 bar (150 psi)
Max. working temperature:	160°C (320°F) dependent on application
Diaphragm material:	EPDM or PTFE
Valve body material:	Forged 1.4435/ 316L ASME/BPE Investment cast 1.4435/ 316L Other Alloys
End connection:	Butt weld ends see fold out page 21 Clamps and flanges see page 22 to 24 Special ends
Bonnets suitable for:	Two-Way bodies Welded configurations T- bodies Multiport bodies Tank bottom bodies
Flow rate:	Kv in m ³ /h (Cv in GPM) see page 9
Diaphragm size:	MA see table
Technical data also valid for multiport valve.	

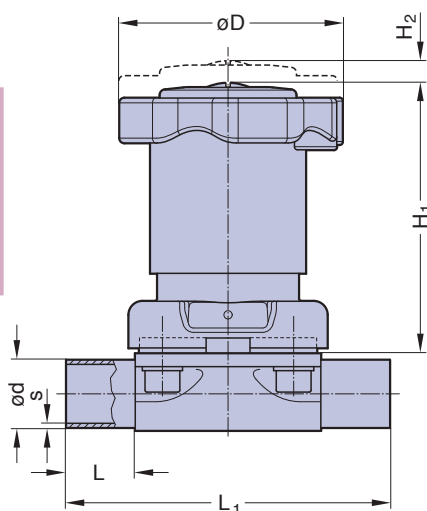

Butt weld ends
MA 25 - 50
Fold out page 21

DN (mm)	MA	Dimensions (mm)					Total weight ca. (kg) KMA 905	
		L	L ₁	H ₁	H ₂	D	Investment cast	Forged
15-25	25	25	120	100	10	84	1,4	1,6
32-40	40	25	153	119	16	112	2,8	3,0
50	50	30	173	136	20	135	3,8	4,6