

## Pneumatically operated Valve DN 15 - 100 mm (3/4" - 4")

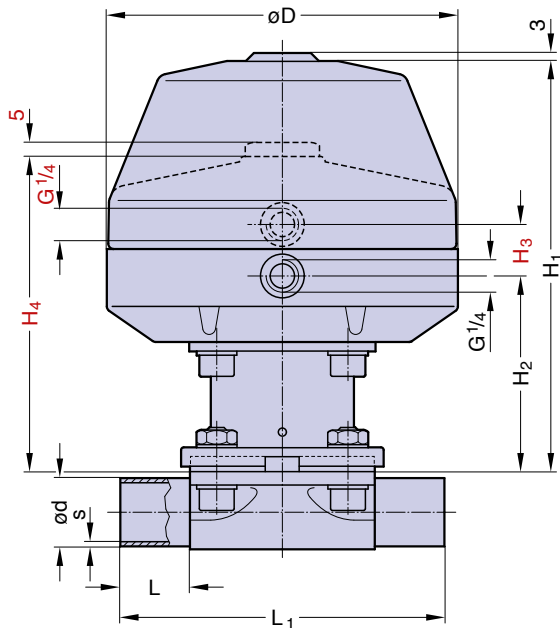

Cf. 1



### Features

- Plastic diaphragm actuator with stainless steel distance piece
- Control air connection 90° to flow direction
- Flexible diaphragm suspension
- Encapsulated diaphragm
- CDSA sealing concept, see page 32

### Optional

- Available with a wide range of control equipment and accessories see page 132 to 139, also for retrofitting

### Technical Data

Control function (Cf.): Pneumatically operated  
 Fail safe close (NC): Cf. 1  
 Fail safe open (NO): Cf. 2  
 Double acting (DA): Cf. 3  
 At control function NO/DA higher control pressure than required may affect the lifetime of the working diaphragm.

#### Direction

Control connection: At Cf. 1, 2 & 3, 90° to flow direction, standard

Max. working pressure: Unidirectional ( $\Delta p = 100\%$ )

Diaphragm	DN 15-50 (1/2"-2")	DN 65-80 (2,5"-3")	DN 100 (4")
EPDM	10 bar (150 psi)	7 bar (100 psi)	6 bar (87 psi)
PTFE	8 bar (115 psi)	6 bar (87 psi)	5 bar (72 psi)

Higher working pressure may be achieved with different actuator. Please consult a SED factory representative for working pressure above the indicated maximum.

Max. working temperature: 160°C (320°F) dependent on application

Control pressure:

Cf. 1	DN 15-50	4,5 - 6 bar (65-87 psi)
Cf. 1	DN 65-80	4,5 - 7 bar (65-100 psi)
Cf. 1	DN 100	5,5 - 7 bar (80-100 psi)
Cf. 2 & 3	DN 15-80	4 - 5,5 bar (60-80 psi)
Cf. 2 & 3	DN 100	5 - 6,5 bar (72-93 psi)

Diaphragm material: EPDM or PTFE

Valve body material: Forged 1.4435/ 316 L ASME/BPE  
 Investment cast 1.4435/ 316 L  
 Other alloys

End connection: Butt weld ends see fold out page 21  
 Clamps and flanges see page 22 to 24  
 Special ends

Actuators suitable for: Two-Way bodies  
 Welded configurations  
 T-bodies  
 Multiport bodies  
 Tank bottom bodies

Flow rate: Kv in m<sup>3</sup>/h (Cv in GPM) see page 9

Diaphragm size: MA see table below

Technical data also valid for multiport valve.

DN (mm)	MA	Dimensions (mm)							D	Total weight ca. (kg)		Filling volume (NL)	
		L	L <sub>1</sub>	H <sub>1</sub>	H <sub>2</sub>	H <sub>3</sub>	H <sub>4</sub>	Investment cast		Forged	NC	NO/DA	
15-25	25	25	120	148	71	31	120	130	1,9	2,0	0,15	0,11	
32-40	40	25	153	194	95	31	144	161	4,7	4,9	0,26	0,23	
50	50	30	173	233	109	31	177	217	7,0	8,0	0,73	0,54	
65	80	30	216	314	166	41	275	265	20,0	23,0	2,30	1,87	
80	80	30	254	314	166	41	275	265	20,0	23,0	2,30	1,87	
100	100	30	305	314	166	41	284	265	29,0	27,0	2,30	2,00	

Note: H3 and H4 only for valves with Cf. 2 and Cf. 3 H1 only for valve with Cf. 1